



SPECIFICATION SHEET

FR SERIES

FR 15/25: 15,000 – 25,000 lbs. (7-11 tonnes)
FR 25/35: 25,000 – 35,000 lbs. (11-16 tonnes)
FR 40/60: 40,000 – 60,000 lbs. (18-27 tonnes)
FR 60/80: 60,000 – 80,000 lbs. (27-36 tonnes)

REV092515



FR SERIES: STANDARD & OPTIONAL EQUIPMENT

Operator Cab

- Meets ANSI B56.1 FOPS operator protection
- Left-hand operator position for optimal line of sight
- Rubber-mounted cab isolated from frame to reduce noise and vibration
- Overhead guard provides safety without obstructing views
- Low, non-skid steps for safe and easy entry/exit
- Adjustable semi-suspension seat and retractable seat belts
- Onboard Load Calculator provides capacities for forks and boom for all counterweight slab variations and chassis extension position
- Master digital display unit provides all vehicle gauges (e.g. oil temperature, fuel level)
- Engine fault code diagnostic capability
- Soft-touch hydraulic levers
- Tilt-steering column
- Spring-apply/hydraulic-release parking brake
- Hydraulic weight scale

Mast & Carriage

- Quick-Change Fork System for quick connect/disconnect of attachments
- Heavy-duty mast rails provide visibility and full capacity at maximum lift heights
- High-strength adjustable composite wear pads on boom
- Main and side thrust rollers are impact-resistant and designed to reduce friction
- Greaseable mast pivots constructed with wear-resistant bronze bushings and hardened steel pins
- Safety valve built into base of lift cylinder securely holds load in event of hose failure
- Chrome-plated cylinder rods

Power

- GM 3.0L LPG (FR 15/25, FR 25/35 and FR 40/60) or GM 4.3L LPG (FR 60/80) engine
- Electronic engine diagnostics with fault code history
- Built-in engine protection system
- Heavy-duty isolated anti-vibration bolt-in drive line mounts
- Inboard muffler
- Heavy-duty alternator with built-in regulator (amps vary with capacity)
- Externally mounted charge pump and integral filter allow for easy maintenance
- O-ring face seal fittings on entire system prevent oil leaks
- Tilt-lock counterbalance valve to prevent mast drift
- Easy-access oil filter and drain for quick and easy maintenance
- Large clean-out covers on top of hydraulic tank for easy access and convenient drain plug on bottom
- Filters are easily accessible for quick replacement
- Electric fan with automated reversing feature to keep radiator clean (only on FR 15/25 and FR 25/35)
- Hydraulic multi-gauge provides quick and easy pressure readings with a twist of the dial; eliminates the need to tap into hydraulic lines
- Standard 12-volt electrical system
- Color-coded electrical wires enclosed with split-tubing wire loom wrap using sealed weather pack connectors

Strength

- Planetary drives rated for durability in high-capacity, high-torque applications
- Double reduction gearing for increased torque
- Precision ground, heat-treated gears

Industrial Steer Axle

- Thick top plate on welded beam steer axle provides added strength
- Highly maneuverable in tight areas
- Dual-action bolt on cylinder is protected by heavy steel support beams and provides effortless power steering
- Lower maintenance costs due to minimal amount of moving parts
- Easy-access lubrication points
- Tapered roller bearings
- High-impact greaseable composite trunnions

Paint/Finish

- Two-part rust-inhibiting polyurethane base coat and two-part polyurethane top coat for corrosion protection
- Majority of components are powder-coated, which is up to 10 times thicker than traditional spray paint resulting in greater scratch and chip resistance
- Environmentally friendly; produces virtually no VOCs

Serviceability

- Hinged panels and hoods supported by gas shocks to reach entire drivetrain, hydraulics and filters
- Hydraulic multi-gauge provides quick and easy pressure readings with a twist of the dial, eliminating the need to tap into individual hydraulic lines
- Every component sourced from a reputable vendor or manufactured by Hoist Liftruck providing cost savings and rapid parts availability

Optional Equipment & Features

- Remote control for all vehicle functions
- Fire extinguisher
- Single- or dual-camera/monitor packages
- Additional two- and three-stage mast options for increased lift heights
- Side-shifting, independent fork positioner (SS/FP)
- Boom attachments: hooks, shackles, swivels and more
- Additional work lights
- Hydraulic service brakes

Note: Specifications in this document apply to standard equipment. Actual specifications and performance may vary depending on custom specifications, equipment condition and operating environment. Specific applications should be reviewed with a Hoist Liftruck representative.



FR SERIES 60/80

60,000 / 80,000 lbs. (27-36 tonnes)

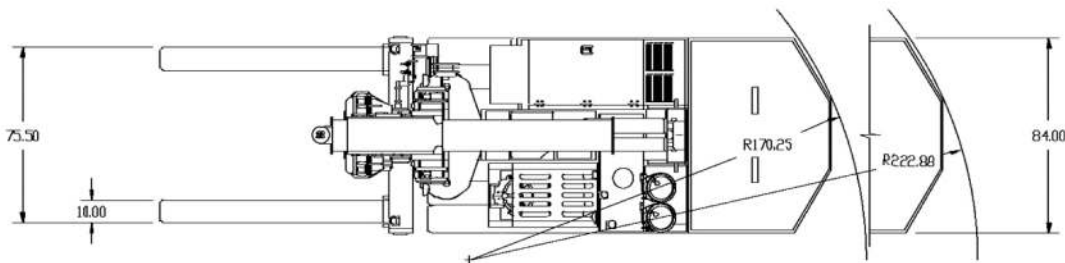

WEIGHTS - lbs (kg)

Counterweight
29,360 (13,317)

Boom
8,500 (3,855)

Forks
4,700 (2,132)

Total
86,530 (39,250)

FORKS ONLY

COUNTERWEIGHT EXTENSION - in (mm)	WHEELBASE in (mm)	LOAD CENTER in (mm)	# OF SLABS	LIFT CAPACITY lbs (kg)
0 (0)	120 (3,048)	36 (914)	0	20,510 (9,303)
0 (0)	120 (3,048)	36 (914)	8	60,000 (27,216)
48 (1,219)	168 (4,267)	36 (914)	0	25,950 (11,771)
48 (1,219)	168 (4,267)	36 (914)	8	80,000 (36,288)

BOOM ONLY

COUNTERWEIGHT EXTENSION - in (mm)	WHEELBASE in (mm)	LOAD CENTER in (mm)	# OF SLABS	LIFT CAPACITY lbs (kg)
0 (0)	120 (3,048)	36 (914)	0	15,500 (7,031)
0 (0)	120 (3,048)	36 (914)	8	48,220 (21,872)
48 (1,219)	168 (4,267)	36 (914)	0	20,040 (9,090)
48 (1,219)	168 (4,267)	36 (914)	8	64,810 (29,398)

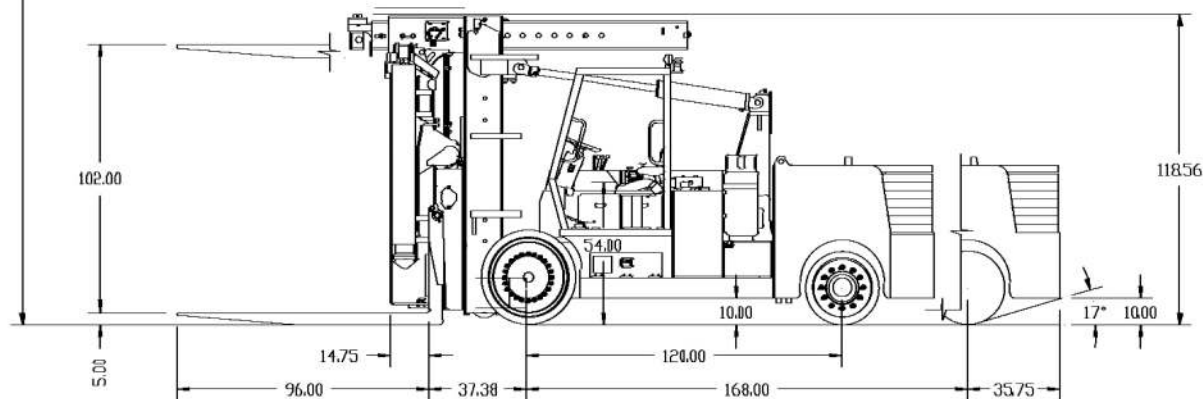
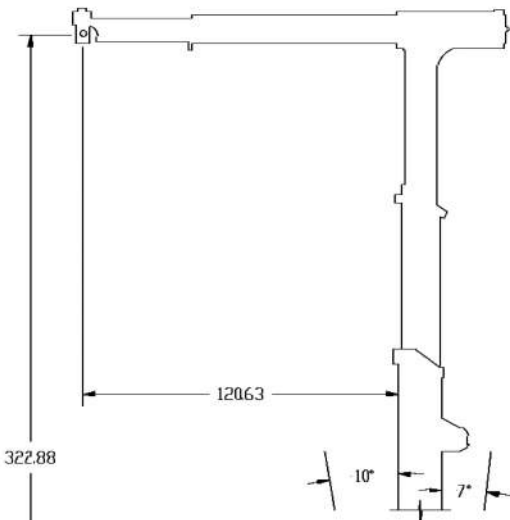

Note: Specifications in this document apply to standard equipment. Actual specifications and performance may vary depending on custom specifications, equipment condition and operating environment. Specific applications should be reviewed with a Hoist Liftruck representative.

