



series 2601

BOOM TRUCKS

features

- 26 Ton (23 mton) Capacity
- 4-Section 101' (30,8 m) Proportional Boom
- 141' 4" (43,1 m) Maximum Tip Height
- 112' 2" (34,2 m) Maximum Main Boom Tip Height
- 1-Section 29' (8,8 m) Jib
- 2-Speed Planetary Hoist with Grooved Drum and Negative Draft Flange
- Load moment system with digital display, CAN bus, overload shutdown, and internal boom length sensing cable
- Radio ATB
- 21' 6" (6,6 m) A-Frame Outriggers
- 10' (3,1 m) A-Frame Stabilizers
- Front bumper stabilizer with auto-retract feature for a 360° area of operation (option).
- Rugged, Weatherproof, Connectorized, Electrical System with Crane System Circuit Status LEDs
- Removable Boom Rest
- System Pressure Gauge
- Clamp-On Mounting
- ManItex UPTIME Comprehensive Support



product guide

series 2601

GENERAL SPECIFICATIONS

BOOM

Booms - Inverted T-cross section, 4-section telescoping type, extended and retracted proportionally by double-acting hydraulic cylinder and cable-crowd system. Easily replaceable and adjustable high-density nylon slide pads. 4-Section, 29' 5" (9,0 m) to 101' (30,8 m). 1-section, 29' (8,8 m) jib.

Quick Reeve Boom Point - Three high-density nylon load sheaves mounted on heavy-duty roller bearings. Three removable pin-type rope guards.

Boom Elevation - Double-acting hydraulic cylinder. Working range from 10° below horizontal to 80.5° above.

Load Hook - 5-ton (4,5 mton) capacity hook with heavy-duty swivel and weight is provided for single-line operation.

HOIST

Maximum theoretical line speed 300 fpm (91,4 mpm). Maximum theoretical bottom-layer line pull 11,500 lb (5 216 kg). Two-speed planetary reducer. Spring applied, pressure-released internal brake.

WIRE ROPE

300' (91,4 m) of 9/16" (14,3 mm) diameter 6 X 25 EIPS IWRC.

SWING SYSTEM

Oversized diameter ball bearing with external gear, 372° non-continuous rotation is standard. Externally mounted, double-reduction planetary driven by hydraulic motor; spring-applied hydraulically released brake. Maximum swing speed 1.5 rpm

OUTRIGGERS

21' 6" (6,6 m) A-frame link type with double-acting hydraulic cylinders operated independently for precise leveling. Bubble level located near outrigger controls. 16" (406,4 mm) x 20" (508 mm) pivoting pad.

STABILIZERS

A-frame type - 8' (2,4 m) retracted; 10' (3,1 m) extended; mounted under truck frame. Operated independently for precise leveling. 8" (203,2 mm) x 11.38" (288,9 mm) fixed pad.

Out-Down type (option) - 8' (2,4 m) retracted; 13' 11" (4,2 m) extended; mounted under truck frame. Operated independently for precise leveling. 12" (305 mm) diameter pivoting pad.

Front Bumper stabilizer (option) - Single stabilizer mounted at the front of the truck for 360° area of operation. Stabilizer cylinder protected by auto-retract feature to prevent drive away damage. This option may require front frame extensions-consult factory.

MOUNTING

Mounting - Pedestal and subframe are mounted to chassis by threaded rods and clamp plates. No welding, drilling or bolting to truck chassis is required.

Rear Underride Protection - Supplied on factory-mounted cranes. Fabricated structure mounted under rear of carrier. Complies with Bureau of Motor Carrier Safety Standard 393.86.

Subframe - Torsion resistant, rigid 4-plate design, mounted under crane; full length of truck frame.

Boom Rest - Heavy-duty fabrication. Easily removed to simplify loading and unloading truck deck.

CONTROL SYSTEM

Dual operator platforms are equipped with four single-axis lever crane controls arranged to ANSI B30.5 standards, fully proportional control valves and system pressure gauge. Each station also includes outrigger and stabilizer controls, engine start/stop, air foot throttle, signal horn, load moment indicator console, boom-angle indicator, load chart and range diagram and beverage container.

HYDRAULICS

Hydraulic System - A 3-section gear pump direct-mounted to power take-off on truck transmission provides 32 gpm (121 lpm) to the hoist, 10 gpm (38 lpm) to the swing and 21 gpm (79,5 lpm) to the remaining crane functions. 70-gallon (265-liter) baffled reservoir with strainer and 25-micron filter in the return lines. Ball-type shutoff valve and strainer are provided in suction line. All fittings are ORS face and SAE O-ring type.

Hydraulic Cylinders - All load-holding cylinders are equipped with integral holding valves.

WARNING SYSTEMS

Load Moment Indicator (LMI) - CAN bus system maximizes expansion capabilities. Senses boom hoist cylinder pressure, boom length and boom angle. Audio-visual warning indicated overload conditions and overload shutoff feature prevents continuing overload. Operator can access all load conditions via display at the operator station. Internal boom length cable.

Radio Anti-Two-Block System - Audible warning and shutoff functions prevent hook from contacting boom point. Wireless system eliminates downtime typically associated with damaged cables in wired systems.

Back-Up Alarm - Electronic audible motion alarm activates when truck transmission is in reverse gear.

GENERAL

Electrical - State-of-the-art, designed with weather-resistant components throughout. Hermetically sealed power in relays. Enclosure includes power in relays and circuit status LEDs. Designed to withstand high-pressure washing and varying climates.

Design/Welding - Design conforms to ANSI B30.5. Welding conforms to AWS D1.1. Tested to SAE 1063 and SAE 765.

Manuals - Operator, service and parts manuals depict correct crane operation, maintenance procedures and parts listing.

Warranty - 12-month warranty covers parts and labor resulting from defects in material and workmanship.

* In order to ensure continuous improvement, specifications may change without notice.

- OAH Overall Height
- CT Cab to Tandem
- CA Cab to Axle
- WB Wheel Base
- OAL Overall Length
- BBC Bumper to Back of Cab
- AF Afterframe

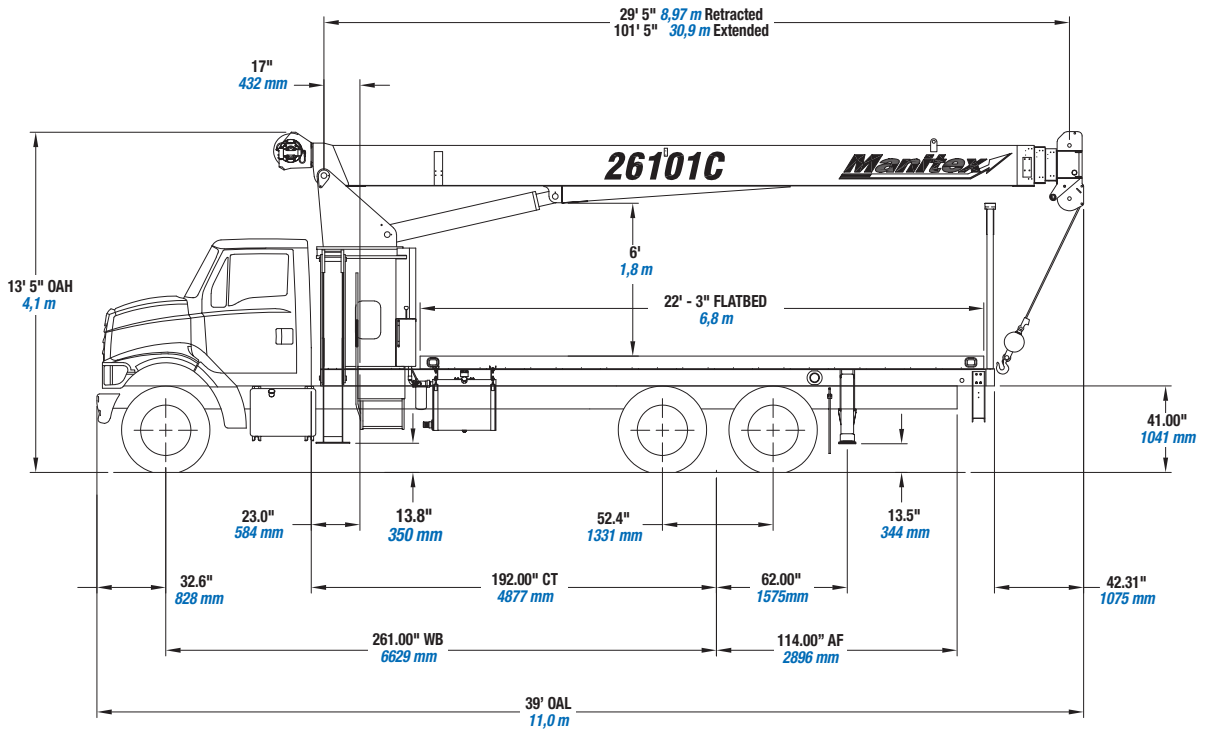

CHASSIS DATA	26101C
Wheelbase (WB)	261" 6 629 mm
Cab to Tandem (CT)	192" 4 877 mm
After Frame (AF)	114" 2 896 mm
Frame Section Modulus	15.9 in ³ 110,000 psi 758 422 kPa
Frame Section Modulus for 360° rotation (minimum)	25.0 in ³ 110,000 psi 758 422 kPa
Front Axle Gross Weight Rating	16,000 lb 7 257 kg
Rear Axle Gross Weight Rating	34,000 lb 15 422 kg
Minimum Truck Axle Weight - Front*	8,000 lb 3 629 kg
Minimum Truck Axle Weight - Back*	8000 lb 3 629 kg
Nominal Frame Width	34"-35" 864 - 889 mm

*Minimum chassis weight is required to meet 85% stability requirements. Chassis data is general - not for engineering. Some dimensions depend on truck selection.

MAXIMUM TIP HEIGHT	26101C
Configuration	Boom 101' 5" 30,9 m
Extended Boom	112' 8" 34,3 m
Fixed Jib	141' 10" 43,2 m

WEIGHTS	26101C
Total Crane	18,970 lb 8 605 kg
29' (8,84 m) Fixed Length Jib	630 lb 286 kg
22' (6,71 m) Flat Bed -	2,000 lb 907 kg

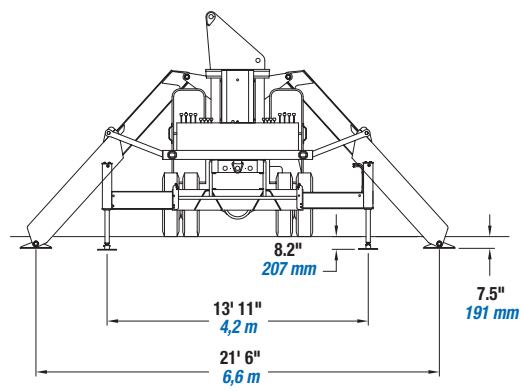

Out-Down Rear Stabilizers (option)

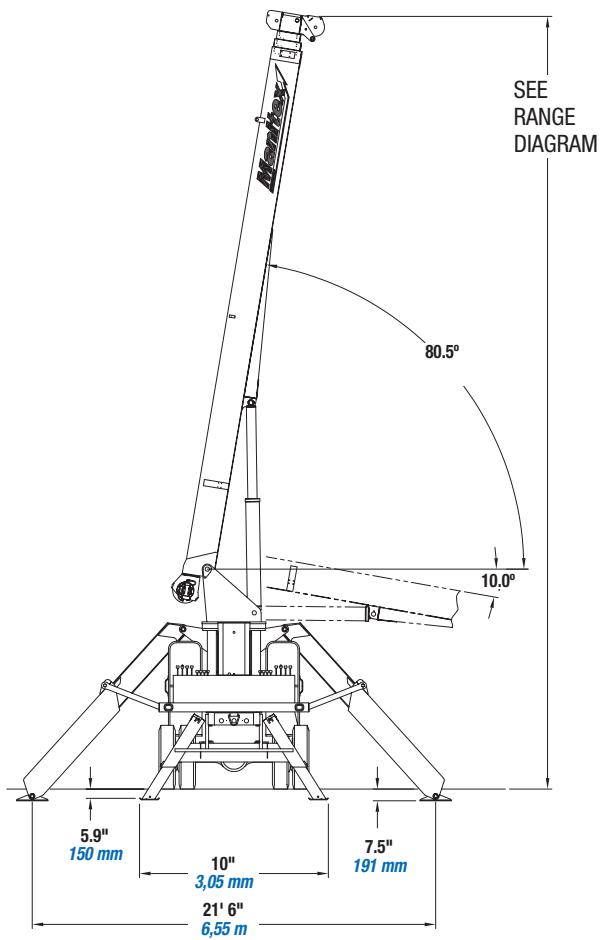

A-frame Rear Stabilizers (standard)

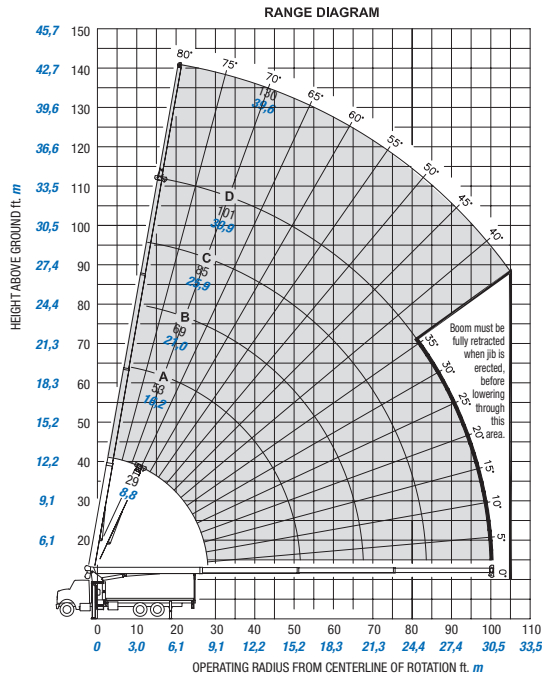

FULLY EXTENDED OUTRIGGER SPREAD: MODEL 26101C																			
MAIN BOOM LOAD RATINGS														JIB LOAD RATINGS					
Operating Radius		Boom Length		A			B			C			D			Fixed Jib			
		29.4 Feet 8.96 Meters		53 Feet 16.15 Meters			69 Feet 21.03 Meters			85 Feet 25.91 Meters			101 Feet 30.78 Meters			26 Feet 7.92 Meters			
Feet	Meter	∠	lb	kg	∠	lb	kg	∠	lb	kg	∠	lb	kg	∠	lb	kg	∠	lb	kg
5	1.52	80	52000	23587															
8	2.44	74	37390	16960															
10	3.05	70	31750	14402															
12	3.66	66	27740	12583	78	14000	6350												
14	4.27	61	24720	11213	76	14000	6350	80	14000	6350									
17	5.18	54	21200	9616	72	14000	6350	78	12880	5842									
20	6.10	46	18030	8178	69	13700	6214	75	11430	5185	79	8920	4046						
25	7.62	29	14120	6405	63	11070	5021	71	9460	4291	75	8000	3629	79	6000	2722			
30	9.14				56	9170	4159	66	8210	3724	72	7070	3207	76	5500	2495	80	3000	1361
35	10.67				49	7850	3561	61	6970	3162	68	6130	2781	73	4980	2259	78	2840	1288
40	12.19				41	6120	2776	56	5980	2712	65	5320	2413	70	4490	2037	76	2620	1188
45	13.72				31	4890	2218	51	5020	2277	61	4640	2105	67	4000	1814	73	2420	1098
50	15.24				17	3950	1792	45	4090	1855	57	4070	1846	64	3580	1624	71	2230	1012
55	16.76							38	3370	1529	52	3440	1560	61	3200	1451	69	2020	916
60	18.29							30	2790	1266	47	2860	1297	57	2850	1293	67	1840	835
65	19.81							19	2310	1048	42	2390	1084	54	2430	1102	64	1670	757
70	21.34										36	1990	903	50	2040	925	62	1520	689
75	22.86										29	1650	748	45	1700	771	59	1380	626
80	24.38										20	1360	617	41	1420	644	56	1230	558
85	25.91													36	1160	526	53	1080	490
90	27.43													30	950	431	50	950	431
95	28.96													22	750	340	47	830	376
100	30.48													3	570	259	44	690	313
105	32.00																40	530	240
			340	154		190	86		150	68		120	54		100	45	DEDUCTIONS FOR STOWED JIBS		

Meets ANSI B30.5 Requirements - Do not operate crane or accessories within 10' (3.05 m) of live power lines.
NOTICE: This chart is for reference only and must not be used for lifting purposes. Consult factory for other boom options.

AREA OF OPERATION

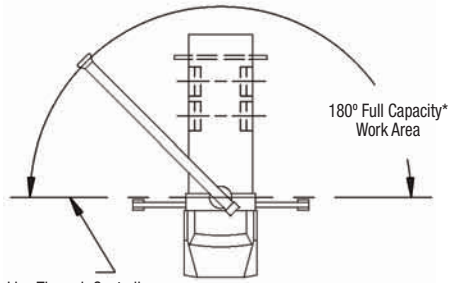

Line Through Centerline of Rotation

* Full capacity 360° work area available if equipped with front stabilizer.

DEDUCTIONS

Auxiliary Block	50 lb 22.72 kg
Auxiliary Sheave	50 lb 22.72 kg
Overhaul Ball	See Overhaul Ball MFG. Nameplate
Load Block	See Block MFG. Nameplate
Hose Reel	140 lb 63.64 kg
Swing Around Jib	See Load Chart

ALLOWABLE LINE PULL

1 Part Line	2 Part Line	3 Part Line	4 Part Line	5 Part Line	6 Part Line	
						<p>WARNING</p> <p>Anti-two-block system must be in good operating condition before operating crane. Refer to the owner's manual. Keep at least three wraps of load line on the drum at all times.</p>
8,500 lb 3 856 kg	17,000 lb 7 711 kg	25,500 lb 11 567 kg	34,000 lb 15 422 kg	42,500 lb 19 278 kg	51,000 lb 23 134 kg	
7,400 lb 3 357 kg	14,800 lb 6 713 kg	22,200 lb 10 070 kg	29,600 lb 13 427 kg	37,000 lb 16 783 kg	44,400 lb 20 140 kg	
						<p>9/16" 6 x 25 IWRC (3.5:1 SF) - 29,750 lb min. breaking strength</p> <p>9/16" rotation resistant (5.0:1 SF) - 37,000 lb min. breaking strength</p>

BOOM AND JIB COMBINATIONS

26101C	101'	4-Section Boom	26' 1-Section Jib

UPTime is the Manitex commitment to complete support of thousands of units working every day.

UPTime

- Includes 24-7-365 parts shipments.
- Utilizes the efficiency of UPNet online parts order system.
- Relies on Manitex's UPTrak support tracking system for performance analysis and resource allocation.
- Features REMan, Manitex's cost effective rebuild/exchange program.
- Provides expert service technicians for troubleshooting and site visits.
- Mandates training; at our facility and yours. It includes coordinated support from all component suppliers.
- Involves every Manitex team member in the support of every Manitex customer.

What does UPTime mean to Manitex customers?

UPTime means reliability.

UPTime means utilization.

UPTime means profitability.



Manitex
3000 South Austin Avenue
Georgetown, TX, USA 78626
Telephone 512-942-3000
Facsimile 512-863-3776
www.manitex.com