

# Grove GMK4100B

## Product Guide



### Features

- 11,0 m – 51 m (36 ft – 167 ft) six-section full power MEGAFORM™ boom with TWIN-LOCK™ pinning
- 8,7 m – 15 m (29 ft – 49 ft) hydraulic offset bi-fold swingaway
- 1 x 6 m (20 ft) intermediate lattice insert
- 19,3 t (42,500 lb) counterweight with hydraulic removal system
- Mercedes-Benz OM 501 LA, 290 kW (390 hp), torque 1850 Nm (1365 ft-lb)
- MEGATRAK™ independent hydro-pneumatic suspension



# Features

## TWIN-LOCK™

Boom pinning mechanism automatically pins the sections in position using two horizontal pins.

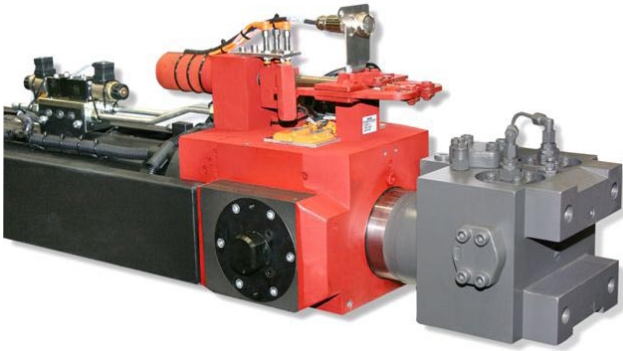

## MEGATRAK™

The MEGATRAK™ suspension system is the best off road driveline available on the market today. The system's versatility and performance allows the GMK4100B to operate as a true all-terrain crane. The MEGATRAK™ independent suspension and all-wheel steer system allows wheels to remain on the ground at all times so stresses and weight are not continually transferred between axles. MEGATRAK™ provides true ground clearance where others just raise the chassis. Other benefits of the MEGATRAK™ system are:

- A reliable suspension system
- Excellent job site maneuverability with all-wheel steering
- Commonality among almost all models
- A driveline that remains aligned at all times
- A steering linkage system that is protected against damage
- Constant tire contact for equal tire wear
- Reduced maintenance

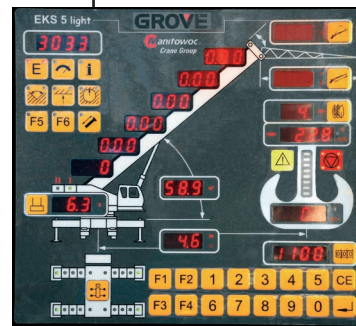

## EKS 5 Light

Monitoring the lifting condition of the crane at all times EKS works together with, but independently of the ECOS as a complete command and control system or separately as a load moment indicator.

## ECOS

Electronic Crane Operating System - ECOS enables control of the entire crane's principle operations. Simple programming eases lift planning and a supply of essential information allows full concentration on the lift itself.



# Contents

Specifications	4
Dimensions	7
Weights	8
Counterweight	9
Working range (Main boom)	10
Load charts (Main boom)	11
Working range (Swingaway and extension)	13
Load charts (Swingaway and extension)	14
Working range (Heavy duty jib)	16
Load charts (Heavy duty jib)	17
Symbols glossary	18

# Specifications

## Superstructure



### Boom

11,0 m – 51 m (36 ft – 167 ft) six section, full power MEGAFORM™ boom with TWIN-LOCK™ pinning. Maximum tip height: 54 m (177 ft).



### Boom nose

Six nylatron sheaves, mounted on heavy-duty tapered roller bearings with removable pin-type rope guards. Quick reeve boom nose. Removable auxiliary boom nose with removable pin type rope guard.



### Boom elevation

Single lift cylinder with safety valve provides boom angle from -3° to +82°.



### Hydraulic offsettable lattice extension

8,7 m – 15 m (29 ft – 49 ft) bi-fold lattice swingaway extension, hydraulically offsettable and luffing under load from 0° - 40°. Maximum tip height: 69 m (226 ft).



### \*Offsettable lattice extension

8,7 m – 15 m (29 ft – 49 ft) bi-fold lattice swingaway extension, manually offsettable at 0°, 20° and 40°. Maximum tip height: 69 m (226 ft).



### \*Lattice extensions

(1) 6 m (20 ft) insert for use with lattice swingaway extension to increase length to 21 m (69 ft). Maximum tip height: 75 m (246 ft).



### Load moment and anti-two block system

Load moment and anti-two block system with audio/visual warning and control lever lockout provides electronic display of boom angle, length, radius, tip height, relative load moment, maximum permissible load, load indication and warning of impending two-block condition.



### Cab

All aluminum constructed cab with acoustical lining, hydraulic tilted to 20°. Includes tinted safety glass, adjustable operator's seat, opening windows at side and rear, hinged windshield with wiper, sun visor and window shade. Other features include diesel heater/defroster, armrest integrated crane controls, drive/steer controls and ergonomically arranged instrumentation.



### Control system

Full electronic control of crane functions using control levers with automatic reset to zero. Integrated with the LMI and engine management systems by CAN-BUS. ECOS system with graphic display.



### Swing

Two axial piston planetary gear boxes with fixed displacement motors. Infinitely variable to 1.8 rpm. Free swing with holding (rocker switch) and service (foot pedal) brake.



### Counterweight

19,3 t (42,500 lb) consisting of various sections with hydraulic installation/removal system controlled from the superstructure cab.



### Hydraulic system

2 separate circuits, 1 axial piston variable displacement pump (load sensing) with electronic power limiting control and 1 gear pump for swing. Thermostatically controlled oil coolers keep oil at optimum operating temperature. Tank capacity: 680 L (180 gal).



### Hoist

Main and auxiliary hoist are powered by axial piston motor with planetary gear and brake. "Thumb-thumper" hoist drum rotation indicator alerts operator of hoist movement.

	Main	Auxiliary
Line length:	220 m (720 ft)	220 m (720 ft)
Rope diameter:	16 mm	16 mm
Line speed:	125 m/min (410 fpm)	125 m/min (410 fpm)
Line pull:	50 kN (11,240 lb)	50 kN (11,240 lb)

# Specifications

## Superstructure, continued

### \*Optional equipment

- ▶ Work lights, mounted on boom base section
- ▶ Boom mounted aircraft warning light
- ▶ Radio/CD player for superstructure cab
- ▶ Air-conditioning
- ▶ Hook blocks/headache ball
- ▶ Additional strobe light
- ▶ Data logger
- ▶ EKS 5 with graphic display in lieu of EKS 5 Light
- ▶ Turntable mounted toolbox
- ▶ 360° positive swing lock (NYC requirement)
- ▶ Working range limiter

## Carrier



### Chassis

Box-type, torsion resistant frame is fabricated from high-strength steel.



### Outrigger system

Four hydraulic single-stage outrigger beams with vertical cylinders and outrigger pads 500 mm (19.7 in) square. Outriggers can be set in four positions:

Full	7 m (23 ft)
Partial	6 m (19.7 ft)
Partial	5 m (16.4 ft)
Retracted	2,3 m (7.6 ft)

Independent horizontal and vertical movement controlled from each side of carrier and the superstructure cab. Electronic crane level indicators.



### Engine

Mercedes-Benz OM 501 LA, 6 cylinder, water cooled, turbo-charged, with 290 kW (390 bhp) @ 1800 rpm. Max. Torque 1850 Nm (1365 ft-lb) @ 1080 rpm. Compression and exhaust brakes. Engine emissions: EUROMOT/EPA/CARB (off road)



### Fuel tank capacity

400 L (106 gal).



### Transmission

ZF, AS Tronic, 12 speeds forward, 2 reverse. 2 speed transfer case.



### Drive/steer

8 x 6 x 8



### Axles

1st axle line - drive/steer

2nd axle line - steer (optional drive)

3rd axle line - drive/steer (connects for all-wheel steer)

4th axle line - drive/steer

Drive axles with planetary hub reduction and center mounted gearing. Inter-axle and cross axle differential locks.



### Suspension

Grove's exclusive MEGATRAK™ suspension. Independent hydro-pneumatic system acting on all wheels with hydraulic lockout. Suspension can be raised 170 mm (6.7 in) or lowered 130 mm (5.1 in) both longitudinally and transversely. Features an automatic leveling system for highway travel.



### Tires

8 tires, 16.00R25 (Vehicle width – 2,75 m [9.0 ft])



### Steering

Dual circuit, hydraulic power assisted steering system. Transfer case mounted, ground driven emergency steering pump. Axles 1, 2, and 4 steer on highway. Separate steering of the 3rd and 4th axles for all wheel steer and crab-steering, controlled by an electronic rocker switch.



### Brakes

Service brakes: pneumatic dual circuit acting on all wheels. Standard anti-lock brake system (ABS).

Parking brake: pneumatically operated spring loaded brake acting on axle lines 2 and 4.

Air dryer.

# Specifications

## Carrier, continued



### Cab

Two-man, aluminum construction includes the following features: safety glass; driver seat with pneumatic suspension, passenger seat, engine-dependent hot water heater, complete instrumentation and driving controls.



### Electrical system

24 V system with three-phase alternator 28 V/100A,  
2 batteries 12 V/170 Ah.



### Maximum speed

85 km/h (53 mph).



### Gradeability (theoretical)

70% with 14.00 tires.

63% with 16.00/20.5 tires.

## Miscellaneous standard equipment

Work lights; tool kit; fire extinguishers; auxiliary boom nose; radio/CD player in carrier cab, heated rear view mirrors, wind speed indicator.

## \*Optional equipment

- ▶ Stainless steel exhaust system with spark arrestor
- ▶ Air-conditioning - combined system
- ▶ 14.00R25 tires (vehicle width 2,55 m [8.4 ft])
- ▶ 20.5R25 tires (vehicle width 2,88 m [9.5 ft])
- ▶ 8x8x8 drive/steer
- ▶ Electric driveline retarder
- ▶ Engine-independent diesel cab heater, with engine pre-heater
- ▶ Timer for diesel heater
- ▶ Strobe light
- ▶ Spare tire and wheel with carry bracket
- ▶ Rear mounted stowage box
- ▶ Outrigger pad load indicator
- ▶ Tool box
- ▶ Engine shut down valve
- ▶ Tiltable carrier cab

# Dimensions

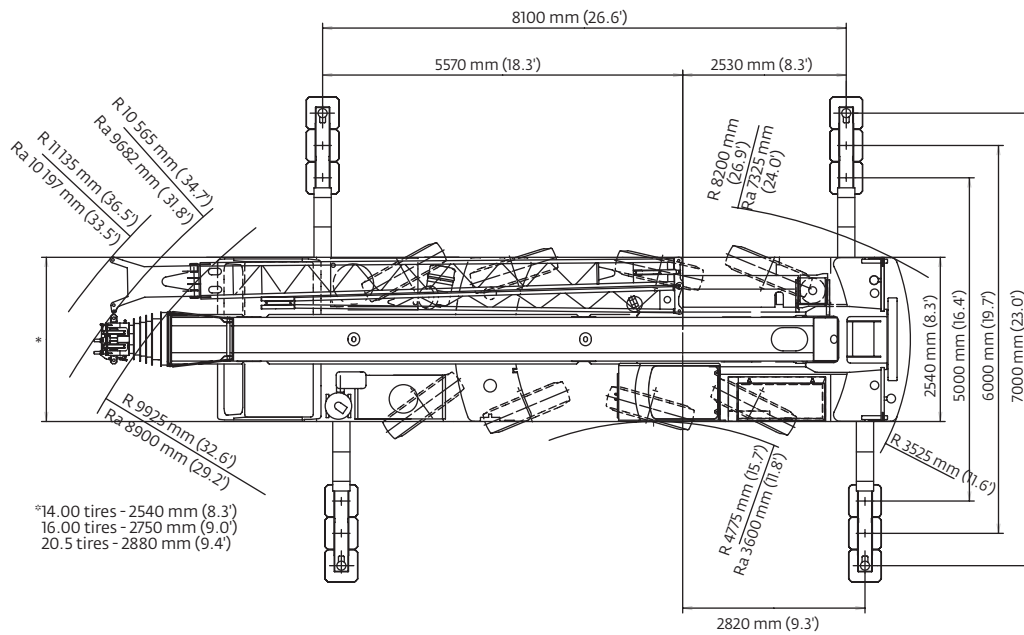
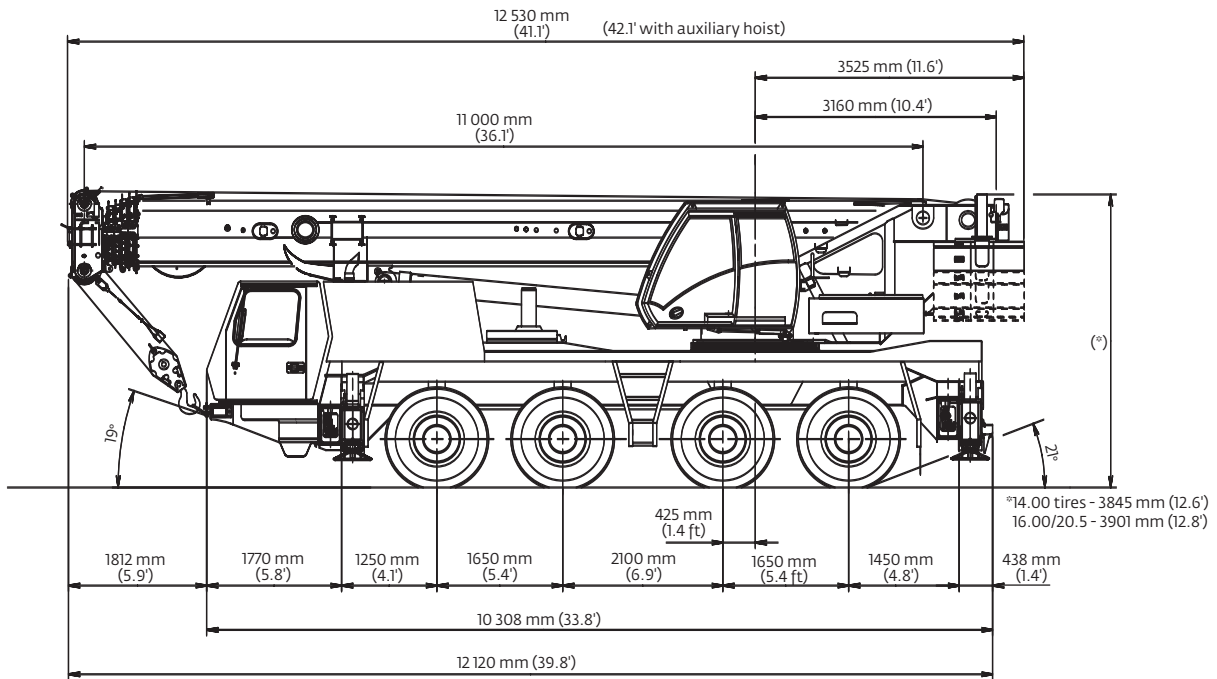

# Weights

## Trailing boom

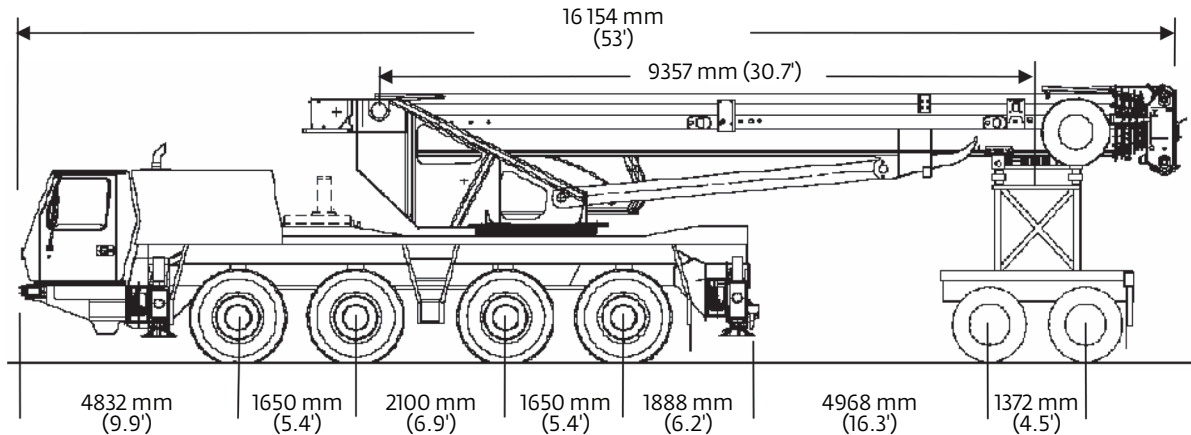

Basic Weights - kg (lb)	Axles 1 and 2		Axles 3 and 4		Dolly		Total	
Mercedes power, 16.00 tires, 8x6x8 drive/steer, outrigger pads stowed, auxiliary hoist, 49 ft swingaway stowed, additional oil cooler, 1300 kg (2866 lb) counterweight slab bolted to superstructure and 2500 kg (5511 lb) counterweight slab clamped to the superstructure and 6000 lb dolly.	22 898	(50,480)	12 714	(28,029)	9759	(21,515)	45 371	(100,024)
<b>Additions:</b>								
14.00R25 tires	-240	(-529)	-240	(-529)	-	-	-480	(-1058)
20.5R25 tires	168	(370)	168	(370)	-	-	336	(740)
8x8x8 drive/steer	265	(584)	75	(165)	-	-	340	(750)
Counterweight in place of auxiliary hoist	-154	(-340)	62	(137)	-	-	-92	(-203)
<b>Removals:</b>								
Hydraulic hose reel	2	(4)	0	(0)	-62	(-137)	-60	(-132)
Brackets for swingaway	-10	(-22)	-5	(-11)	-50	(-110)	-65	(-143)
12 m – 21 m (29.5 ft – 49 ft) swingaway	-183	(-403)	-81	(-179)	-621	(-1369)	-885	(-1951)
Front and rear outrigger floats	-66	(-146)	-74	(-163)	-	-	-140	(-309)
2500 kg (5511 lb) counterweight slab	-2245	(-4949)	-255	(-562)	-	-	-2500	(-5511)
<b>Weight effect:</b>								
Telescope section 1 extended 1 ft	-165	(-364)	-73	(-161)	238	(525)	-	-

## Boom over front

Basic Weights - kg (lb)	Axles 1 and 2		Axles 3 and 4		Total	
Mercedes power, 28.5 ft – 49.2 ft hydraulic offset swingaway including brackets and hose reel, 16.00R25 tires, 8x6x8 drive/steer, 2nd oil cooler, outrigger pads, auxiliary hoist, 1300 kg (2866 lb) counterweight bolted and 2500 kg (5511 lb) counterweight clamped to superstructure, driver and tanks filled.	20 505	(45,205)	22 175	(48,887)	42 680	(94,092)
<b>Additions:</b>						
8x8x8 drive/steer	265	(585)	75	(165)	340	(750)
Electric driveline retarder	-33	(-73)	293	(646)	260	(573)
Spare wheel 14.00 R25 XGC steel rim with stowage	-205	(-452)	470	(1036)	265	(584)
Spare wheel 16.00 R25 XGC steel rim with stowage	-254	(-559)	579	(1275)	325	(716)
Spare wheel 20.5 R25 XGC steel rim with stowage	-291	(-641)	658	(1450)	367	(809)
2500 kg (5511 lb) counterweight slab clamped to superstructure	-1657	(-3653)	4077	(8989)	2420	(5335)
5000 kg (11,023 lb) counterweight slab clamped to superstructure	-3328	(-7337)	8188	(80,052)	4860	(10,714)
2500 kg (5511 lb) counterweight slab on carrier deck (base plate)	2281	(5029)	259	(570)	2540	(5600)
5000 kg (11,023 lb) counterweight slab on carrier deck	4365	(9623)	495	(1091)	4860	(10,714)
<b>Substitutions:</b>						
14.00R25 tires	-265	(-584)	-265	(-584)	-530	(-1168)
20.5R25 tires	168	(370)	168	(370)	36	(741)
<b>Removals:</b>						
Brackets for hydraulic swingaway	-93	(-206)	28	(63)	-65	(-143)
Hose reel for hydraulic swingaway	-125	(-275)	65	(143)	-60	(-132)
10 m – 17 m (33 ft – 56 ft) hydraulic swingaway	-1245	(-2744)	360	(793)	-885	(-1951)
Auxiliary boom nose	-142	(-314)	82	(182)	-60	(-132)
Outrigger floats front	-109	(-240)	39	(85)	-70	(-154)
Outrigger floats rear	42	(94)	-112	(-248)	-70	(-154)

THIS CHART IS ONLY A GUIDE AND SHOULD NOT BE USED TO OPERATE THE CRANE.

The individual crane's load chart, operating instructions and other instructional plates must be read and understood prior to operating the crane.



# Counterweight

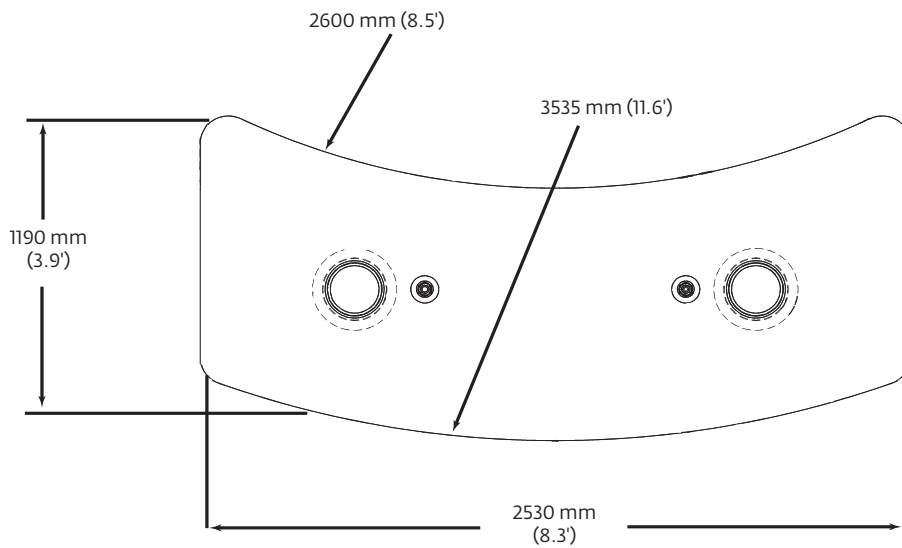
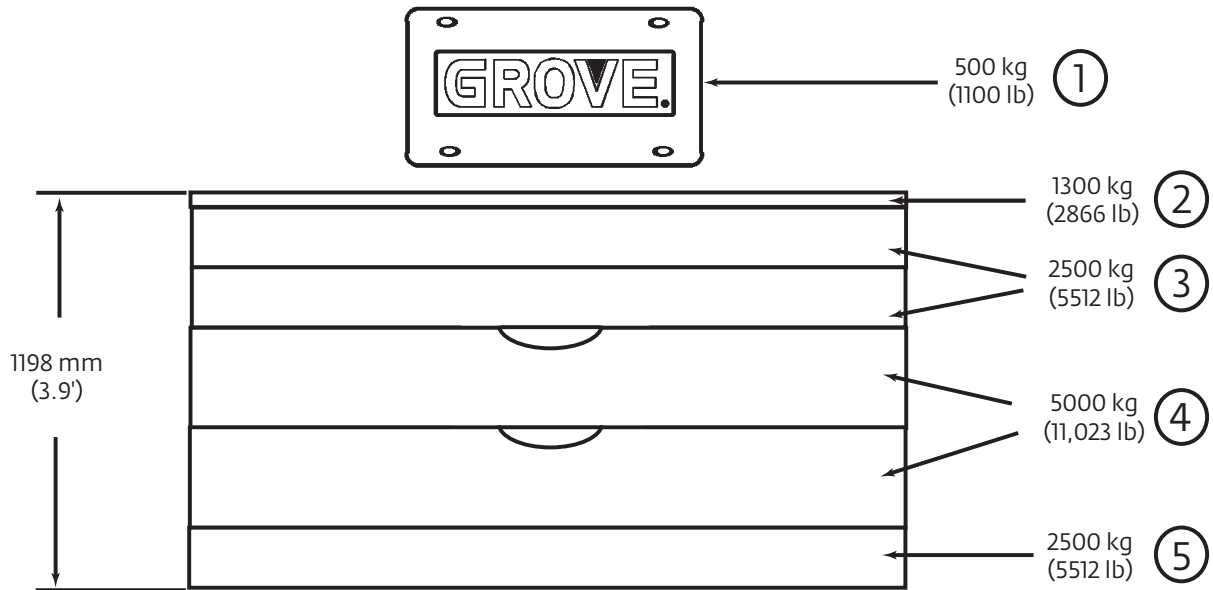

**Counterweight configurations**

kg (lb)	1	2	3	4	5
1800 (3900)	X	X			
4300 (9400)	X	X			X
6800 (14,900)	X	X	X		X
9300 (20,500)	X	X		X	X
11 800 (26,000)	X	X	X	X	X
14 300 (31,500)	X	X		2x	X
16 800 (37,000)	X	X	X	2x	X
19 300 (42,500)	X	X	2x	2x	X

# Working range

36 ft – 167 ft main boom

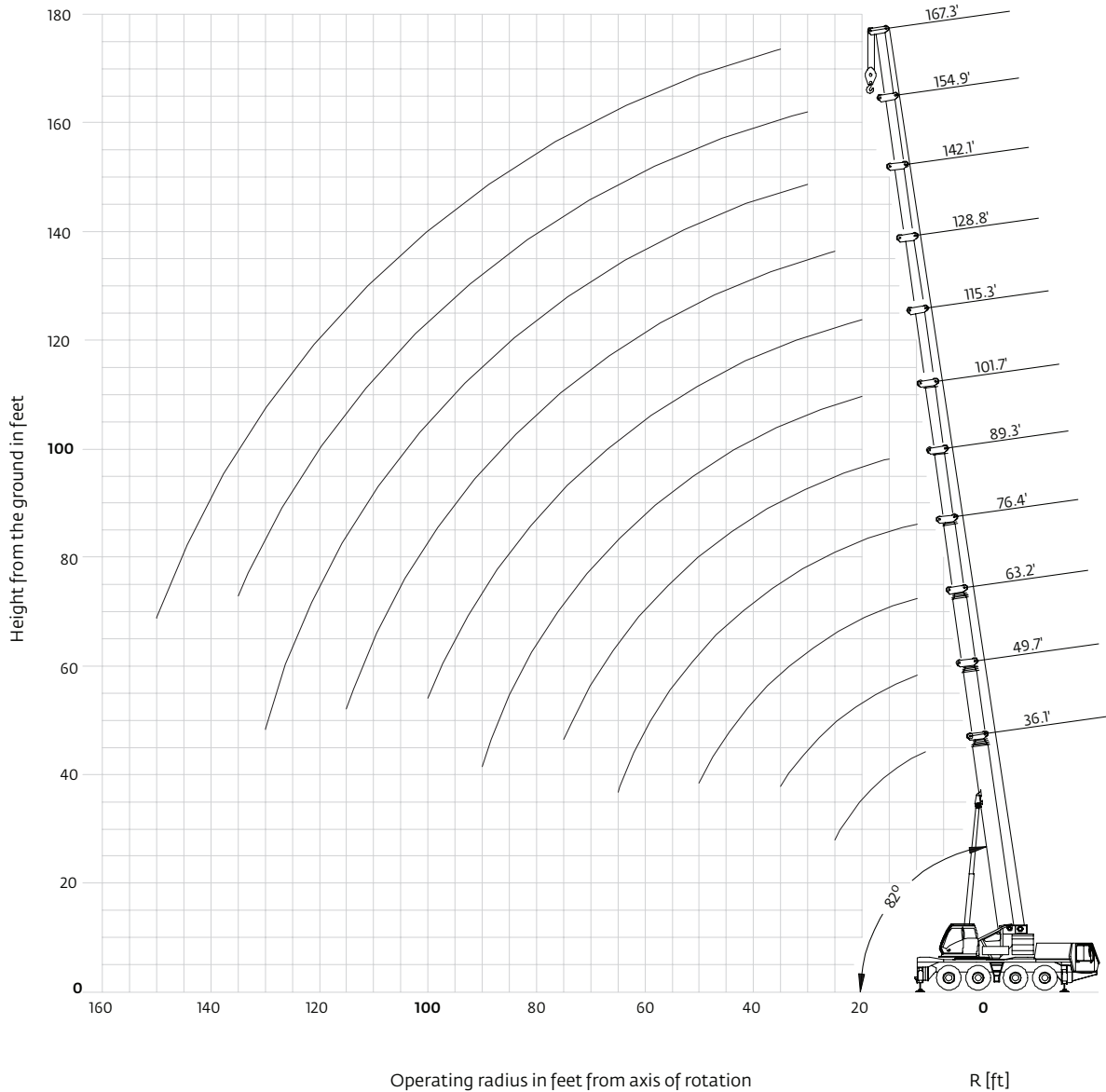

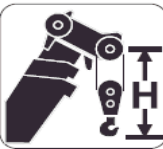
	Hook block	H
		80 USt, 7 sheave quick-reeving
	55 USt, 5 sheave quick-reeving	3000 mm (9.8 ft)
	35 USt, 3 sheave quick-reeving	2900 mm (9.5 ft)
	15 USt, 1 sheave quick-reeving	2800 mm (9.2 ft)
	6 USt, 7 single headache ball	2350 mm (7.7 ft)

*Tip heights shown in the working range diagram do not consider loaded boom deflection.*

# Load charts

## Main boom

		Pounds x 1000									
Feet	36.1	49.7	63.2	76.4	89.3	101.7	115.3	128.8	142.1	154.9	167.3
8	* 200.0										
10	154.0	132.0	123.0	109.0							
15	114.0	109.0	102.0	95.0	80.0						
20	92.0	90.0	87.0	81.0	76.0	61.0	45.0				
25	71.0	73.0	73.0	67.0	66.0	58.0	45.0	33.8			
30		59.0	56.0	56.0	52.0	51.0	41.8	33.8	25.4	19.6	
35		47.0	48.0	45.0	45.0	42.2	37.8	33.0	25.4	19.6	15.8
40			38.8	38.0	38.0	35.6	33.4	30.4	25.4	19.6	15.8
45			32.4	32.6	32.6	30.4	28.6	27.6	25.4	19.6	15.8
50			27.4	28.8	28.4	26.4	25.2	23.8	23.6	19.6	15.8
55				24.8	24.4	23.0	23.6	20.8	20.6	19.4	15.8
60				21.6	21.4	20.4	20.8	18.2	18.2	18.2	15.8
65				19.2	18.8	19.0	18.6	16.6	16.0	16.2	15.6
70					16.6	17.4	16.6	15.6	14.6	14.4	14.8
75					14.6	15.6	14.6	14.8	13.6	13.4	13.2
80						14.0	13.0	13.4	12.8	12.4	11.8
85						12.4	11.6	12.0	12.0	11.4	10.8
90						9.4	10.4	10.8	10.8	10.6	9.6
95							9.2	9.8	9.8	9.6	8.8
100							8.4	9.0	8.8	8.6	7.8
105								8.4	8.0	7.8	7.0
110								7.8	7.4	7.0	6.4
115								4.2	6.8	6.2	5.6
120									6.0	5.6	5.0
125									3.4	5.0	4.4
130									2.8	4.4	3.8
135										4.0	3.4
140											2.8
145											2.4
150											2.0

\* 0° over rear with special equipment  
 Loads above 130,000 lb require additional equipment

		Pounds x 1000									
Feet	36.1	49.7	63.2	76.4	89.3	101.7	115.3	128.8	142.1	154.9	167.3
10	154.0	132.0	123.0	109.0							
15	114.0	109.0	102.0	95.0	80.0						
20	92.0	90.0	87.0	81.0	76.0	61.0	45.0				
25	71.0	72.0	68.0	65.0	62.0	58.0	45.0	33.8			
30		57.0	54.0	52.0	51.0	48.0	41.8	33.8	25.4	19.6	
35		44.0	45.0	42.6	42.4	39.6	37.2	33.0	25.4	19.6	15.8
40			36.4	36.0	35.6	33.2	31.2	30.0	25.4	19.6	15.8
45			30.2	31.6	30.6	28.4	27.0	25.6	25.2	19.6	15.8
50			25.6	26.8	26.4	24.4	25.0	22.0	21.8	19.6	15.8
55				23.2	22.8	21.4	21.8	19.2	19.0	19.2	15.8
60				20.2	19.8	20.2	19.4	17.6	16.6	16.8	15.8
65				17.8	17.4	18.2	17.2	16.6	15.6	15.4	15.2
70					15.2	16.2	15.2	15.4	14.6	14.4	13.4
75					13.4	14.4	13.4	13.8	13.6	13.0	12.0
80						12.8	12.0	12.4	12.2	11.8	10.8
85						11.4	10.6	11.0	11.0	10.6	9.6
90						8.6	9.4	10.2	10.0	9.6	8.6
95							8.4	9.4	9.0	8.6	7.8
100								7.4	8.6	8.2	7.0
105									7.8	7.4	6.2
110									7.2	6.6	5.6
115									3.4	6.0	4.8
120										5.4	4.2
125										2.6	3.6
130										2.2	3.2
135											2.6
140											2.2
145											1.8

Loads above 130,000 lb require additional equipment

THIS CHART IS ONLY A GUIDE AND SHOULD NOT BE USED TO OPERATE THE CRANE.

Grove GMK4100B The individual crane's load chart, operating instructions and other instructional plates must be read and understood prior to operating the crane

# Load charts

## Main boom







11,0 m – 51 m  
 (36 ft – 167 ft)

9300 kg  
 (20,500 lb)

26.6 ft x 23.0 ft  
 (100%)

360°



**Pounds x 1000**

Feet	36.1	49.7	63.2	76.4	89.3	101.7	115.3	128.8	142.1	154.9	167.3
10	154.0	132.0	123.0	109.0							
15	114.0	109.0	102.0	95.0	80.0						
20	85.0	80.0	74.0	67.0	65.0	61.0	45.0				
25	60.0	58.0	56.0	53.0	52.0	48.0	44.0	33.8			
30		45.0	43.6	43.2	40.8	37.6	35.0	33.4	25.4	19.6	
35		34.6	36.6	35.2	33.2	30.8	30.8	27.4	25.4	19.6	15.8
40			29.6	29.4	27.6	27.2	25.8	23.6	22.4	19.6	15.8
45			24.4	24.8	23.4	23.8	22.0	21.8	20.4	19.0	15.8
50			20.6	20.8	20.2	20.6	19.0	18.8	18.6	17.6	15.8
55				17.8	17.4	18.0	16.4	16.8	16.4	15.4	14.2
60				15.8	14.8	15.8	14.4	15.2	14.4	13.4	12.4
65				14.0	12.8	13.6	13.2	13.6	12.8	11.8	10.8
70					11.0	12.0	12.2	12.0	11.2	10.4	9.4
75					9.6	10.4	11.0	10.8	10.0	9.2	8.2
80						9.6	9.8	9.6	9.0	8.2	7.2
85						8.8	8.6	8.4	8.0	7.2	6.2
90						5.2	7.6	7.4	7.0	6.4	5.4
95							6.8	6.6	6.2	5.6	4.6
100							4.6	5.8	5.4	4.8	4.0
105								5.2	4.6	4.2	3.4
110								4.4	4.0	3.6	2.8
115									3.4	3.0	2.2
120									3.0	2.4	1.8
125										2.0	

Loads above 130,000 lb require additional equipment







11,0 m – 51 m  
 (36 ft – 167 ft)

1800 kg  
 (3900 lb)

26.6 ft x 23.0 ft  
 (100%)

360°



**Pounds x 1000**

Feet	36.1	49.7	63.2	76.4	89.3	101.7	115.3	128.8	142.1	154.9	167.3
10	154.0	132.0	123.0	109.0							
15	108.0	98.0	87.0	77.0	72.0						
20	65.0	60.0	58.0	56.0	52.0	47.0	43.4				
25	44.0	44.0	44.0	41.8	38.8	35.4	32.6	30.8			
30		34.0	33.8	32.2	30.2	30.2	27.6	27.0	23.4	19.6	
35		25.8	27.0	26.0	24.2	24.4	22.6	23.0	21.2	18.4	15.8
40			21.6	21.8	19.6	20.0	20.0	19.0	17.8	16.4	15.0
45			17.4	18.6	16.0	17.0	16.8	15.8	14.8	13.6	12.4
50			14.2	15.4	13.8	15.0	14.2	13.4	12.4	11.4	10.2
55				12.8	12.4	12.8	12.0	11.4	10.6	9.6	8.4
60				10.6	11.0	11.0	10.4	9.8	9.0	8.0	7.0
65				9.0	9.2	9.6	9.0	8.4	7.6	6.8	5.8
70					7.8	8.0	7.8	7.2	6.4	5.6	4.6
75					6.6	6.8	6.6	6.2	5.4	4.8	3.8
80						5.8	5.6	5.2	4.6	3.8	3.0
85						5.0	4.8	4.6	3.8	3.2	2.2
90							4.0	3.8	3.2	2.6	
95							3.4	3.0	2.6	2.0	
100								2.6	2.0		
105									2.0		

Loads above 130,000 lb require additional equipment

THIS CHART IS ONLY A GUIDE AND SHOULD NOT BE USED TO OPERATE THE CRANE.

The individual crane's load chart, operating instructions and other instructional plates must be read and understood prior to operating the crane.

# Working range



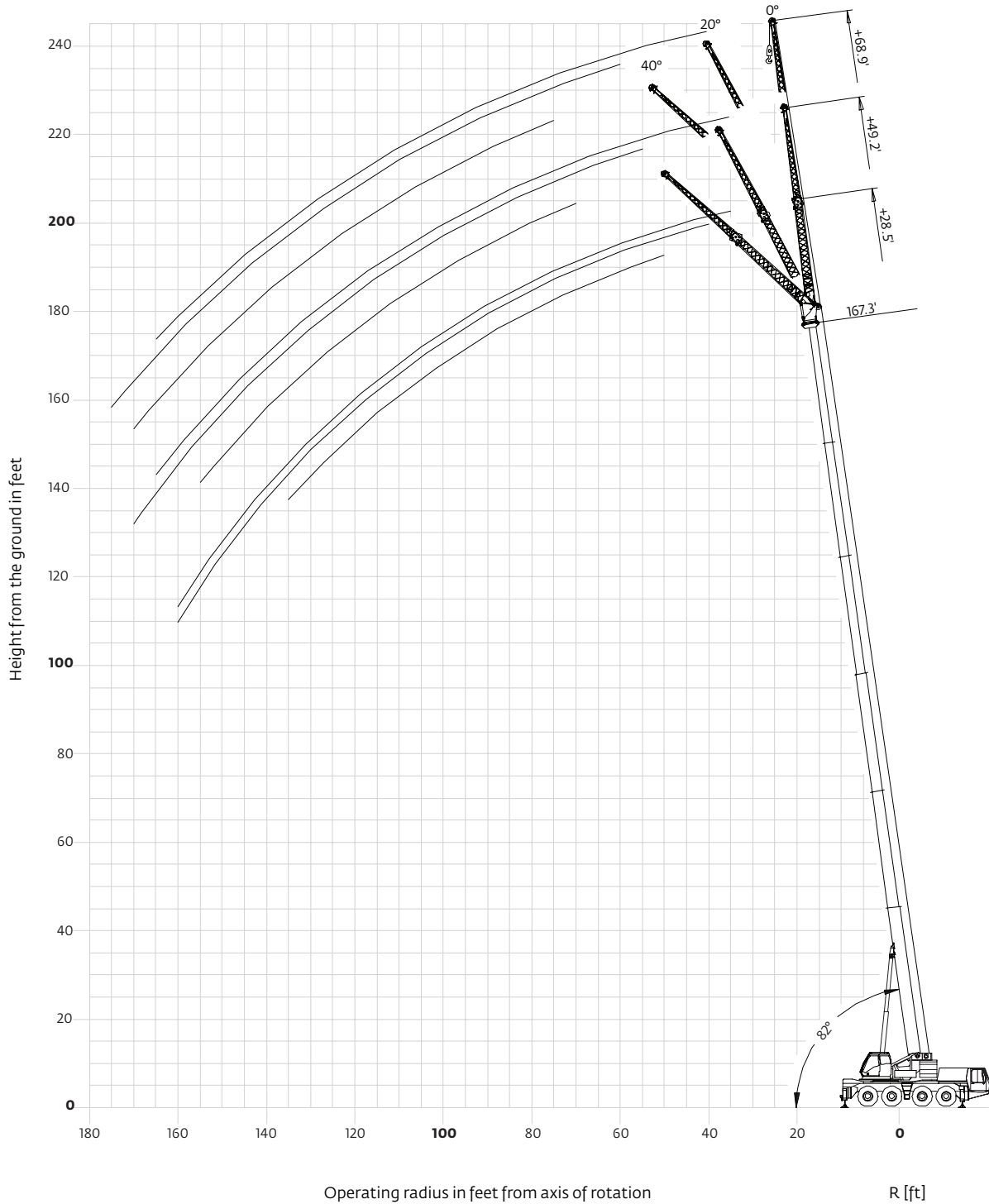

167.3 ft main boom with hydraulic luffing 28.5 ft and 49.2 ft swingaway and 1 x 19.7 ft insert





# Load charts

## Hydraulic offsettable swingaway

### Intermediate angle











51 m (167 ft)      8,7-15-21 m (29-49-69 ft) Hydraulic luffing      19 300 kg (42,500 lb)      26.6 ft x 23.0 ft (100%)      360° 100%





**Pounds x 1000**

Feet	167.3 ft + 28.5 ft			167.3 ft + 49.2 ft			167.3 ft + 68.9 ft		
	0°	0°-20°	20°-40°	0°	0°-20°	20°-40°	0°	0°-20°	20°-40°
35	8.6			5.0					
40	8.6	8.6		5.0			4.2		
45	8.6	8.6		5.0			4.2		
50	8.6	8.6	7.4	5.0			4.2		
55	8.6	8.4	7.4	5.0	5.0		4.2		
60	8.6	8.4	7.2	5.0	4.8		4.2	4.2	
65	8.6	8.2	7.2	5.0	4.6		4.2	4.2	
70	8.6	8.0	7.0	5.0	4.6	3.8	4.2	4.2	
75	8.6	7.8	7.0	5.0	4.4	3.8	4.2	4.2	3.6
80	8.6	7.8	7.0	5.0	4.4	3.6	4.2	4.2	3.6
85	8.6	7.6	6.8	5.0	4.2	3.6	4.2	4.2	3.6
90	8.6	7.4	6.8	5.0	4.2	3.6	4.2	4.0	3.6
95	8.4	7.4	6.8	5.0	4.0	3.6	4.2	4.0	3.4
100	7.6	7.2	6.8	5.0	4.0	3.4	4.2	4.0	3.4
105	6.8	6.8	6.8	4.8	3.8	3.4	4.2	3.8	3.4
110	6.0	6.0	6.6	4.6	3.8	3.4	4.2	3.8	3.4
115	5.4	5.4	5.8	4.6	3.8	3.4	4.2	3.8	3.4
120	4.8	4.8	5.2	4.4	3.6	3.4	4.2	3.6	3.4
125	4.4	4.4	4.6	4.4	3.6	3.4	4.2	3.6	3.4
130	3.8	3.8	4.2	4.2	3.6	3.4	4.2	3.6	3.4
135	3.4	3.4	3.6	3.8	3.6	3.4	3.8	3.6	3.2
140	2.8	2.8		3.4	3.4	3.4	3.2	3.2	3.2
145	2.4	2.4		3.0	3.0	3.4	3.0	3.0	3.2
150	2.0	2.0		2.6	2.6	3.2	2.6	2.6	3.0
155	1.6	1.6		2.2	2.2	2.8	2.2	2.2	2.6
160	1.4	1.4		1.8	1.8		1.8	1.8	2.4
165				1.6	1.6		1.6	1.6	2.0
170									1.6

### Intermediate angle

51 m (167 ft)      8,7-15-21 m (29-49-69 ft) Hydraulic luffing      16 800 kg (37,000 lb)      26.6 ft x 23.0 ft (100%)      360° 100%



**Pounds x 1000**

Feet	167.3 ft + 28.5 ft			167.3 ft + 49.2 ft			167.3 ft + 68.9 ft		
	0°	0°-20°	20°-40°	0°	0°-20°	20°-40°	0°	0°-20°	20°-40°
35	8.6			5.0					
40	8.6	8.6		5.0			4.2		
45	8.6	8.6		5.0			4.2		
50	8.6	8.6	7.4	5.0			4.2		
55	8.6	8.4	7.4	5.0	5.0		4.2		
60	8.6	8.4	7.2	5.0	4.8		4.2	4.2	
65	8.6	8.2	7.2	5.0	4.6		4.2	4.2	
70	8.6	8.0	7.0	5.0	4.6	3.8	4.2	4.2	
75	8.6	7.8	7.0	5.0	4.4	3.8	4.2	4.2	3.6
80	8.6	7.8	7.0	5.0	4.4	3.6	4.2	4.2	3.6
85	8.6	7.6	6.8	5.0	4.2	3.6	4.2	4.2	3.6
90	8.2	7.4	6.8	5.0	4.2	3.6	4.2	4.0	3.6
95	7.4	7.4	6.8	5.0	4.0	3.6	4.2	4.0	3.4
100	6.6	6.6	6.8	5.0	4.0	3.4	4.2	4.0	3.4
105	6.0	6.0	6.4	4.8	3.8	3.4	4.2	3.8	3.4
110	5.2	5.2	5.8	4.6	3.8	3.4	4.2	3.8	3.4
115	4.6	4.6	5.0	4.6	3.8	3.4	4.2	3.8	3.4
120	4.2	4.2	4.6	4.4	3.6	3.4	4.2	3.6	3.4
125	3.6	3.6	4.0	4.0	3.6	3.4	4.0	3.6	3.4
130	3.2	3.2	3.4	3.6	3.6	3.4	3.4	3.4	3.4
135	2.6	2.6	3.0	3.2	3.2	3.4	3.0	3.0	3.2
140	2.2	2.2		2.8	2.8	3.4	2.6	2.6	3.2
145	1.8	1.8		2.4	2.4	3.0	2.2	2.2	2.8
150	1.4	1.4		2.0	2.0	2.6	2.0	2.0	2.4
155				1.6	1.6	2.2	1.6	1.6	2.2
160				1.4	1.4		1.4	1.4	1.8
165									1.4

THIS CHART IS ONLY A GUIDE AND SHOULD NOT BE USED TO OPERATE THE CRANE.

The individual crane's load chart, operating instructions and other instructional plates must be read and understood prior to operating the crane.

# Load charts

## Manual offsettable swingaway

### Fixed angle

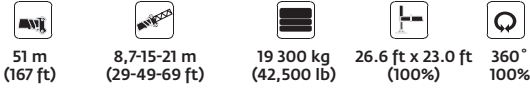

Pounds x 1000

Feet	167.3 ft + 28.5 ft			167.3 ft + 49.2 ft			167.3 ft + 68.9 ft		
	0°	20°	40°	0°	20°	40°	0°	20°	40°
35	8.6			5.0					
40	8.6	8.6		5.0			4.2		
45	8.6	8.6		5.0			4.2		
50	8.6	8.6	7.4	5.0			4.2		
55	8.6	8.4	7.4	5.0	5.0		4.2		
60	8.6	8.4	7.2	5.0	4.8		4.2	4.2	
65	8.6	8.2	7.2	5.0	4.6		4.2	4.2	
70	8.6	8.0	7.0	5.0	4.6	3.8	4.2	4.2	
75	8.6	7.8	7.0	5.0	4.4	3.8	4.2	4.2	3.6
80	8.6	7.8	7.0	5.0	4.4	3.6	4.2	4.2	3.6
85	8.6	7.6	6.8	5.0	4.2	3.6	4.2	4.2	3.6
90	8.6	7.4	6.8	5.0	4.2	3.6	4.2	4.0	3.6
95	8.4	7.4	6.8	5.0	4.0	3.6	4.2	4.0	3.4
100	7.6	7.2	6.8	5.0	4.0	3.4	4.2	4.0	3.4
105	6.8	7.2	6.8	4.8	3.8	3.4	4.2	3.8	3.4
110	6.0	6.6	6.8	4.6	3.8	3.4	4.2	3.8	3.4
115	5.4	5.8	6.2	4.6	3.8	3.4	4.2	3.8	3.4
120	4.8	5.2	5.4	4.4	3.6	3.4	4.2	3.6	3.4
125	4.4	4.6	4.8	4.4	3.6	3.4	4.2	3.6	3.4
130	3.8	4.2	4.4	4.2	3.6	3.4	4.2	3.6	3.4
135	3.4	3.6	3.8	3.8	3.6	3.4	3.8	3.6	3.2
140	2.8	3.2		3.4	3.4	3.4	3.2	3.4	3.2
145	2.4	2.6		3.0	3.4	3.4	3.0	3.4	3.2
150	2.0	2.2		2.6	3.2	3.4	2.6	3.0	3.2
155	1.6	1.8		2.2	2.8	3.0	2.2	2.6	3.0
160	1.4	1.4		1.8	2.4		1.8	2.4	2.6
165				1.6	2.0		1.6	2.0	2.2
170					1.6			1.6	1.8
175								1.4	

### Fixed angle

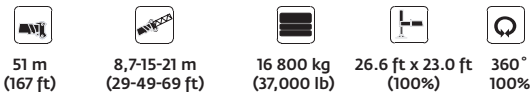

Pounds x 1000

Feet	167.3 ft + 28.5 ft			167.3 ft + 49.2 ft			167.3 ft + 68.9 ft		
	0°	20°	40°	0°	20°	40°	0°	20°	40°
35	8.6			5.0					
40	8.6	8.6		5.0			4.2		
45	8.6	8.6		5.0			4.2		
50	8.6	8.6	7.4	5.0			4.2		
55	8.6	8.4	7.4	5.0	5.0		4.2		
60	8.6	8.4	7.2	5.0	4.8		4.2	4.2	
65	8.6	8.2	7.2	5.0	4.6		4.2	4.2	
70	8.6	8.0	7.0	5.0	4.6	3.8	4.2	4.2	
75	8.6	7.8	7.0	5.0	4.4	3.8	4.2	4.2	3.6
80	8.6	7.8	7.0	5.0	4.4	3.6	4.2	4.2	3.6
85	8.6	7.6	6.8	5.0	4.2	3.6	4.2	4.2	3.6
90	8.2	7.4	6.8	5.0	4.2	3.6	4.2	4.0	3.6
95	7.4	7.4	6.8	5.0	4.0	3.6	4.2	4.0	3.4
100	6.6	7.2	6.8	5.0	4.0	3.4	4.2	4.0	3.4
105	6.0	6.4	6.8	4.8	3.8	3.4	4.2	3.8	3.4
110	5.2	5.8	6.0	4.6	3.8	3.4	4.2	3.8	3.4
115	4.6	5.0	5.4	4.6	3.8	3.4	4.2	3.8	3.4
120	4.2	4.6	4.8	4.4	3.6	3.4	4.2	3.6	3.4
125	3.6	4.0	4.2	4.0	3.6	3.4	4.0	3.6	3.4
130	3.2	3.4	3.6	3.6	3.6	3.4	3.4	3.6	3.4
135	2.6	3.0	3.2	3.2	3.6	3.4	3.0	3.6	3.2
140	2.2	2.6		2.8	3.4	3.4	2.6	3.2	3.2
145	1.8	2.0		2.4	3.0	3.2	2.2	2.8	3.2
150	1.4	1.6		2.0	2.6	2.8	2.0	2.4	2.8
155		1.4		1.6	2.2	2.4	1.6	2.2	2.4
160				1.4	1.8		1.4	1.8	2.0
165					1.4			1.4	1.8
170									1.4

THIS CHART IS ONLY A GUIDE AND SHOULD NOT BE USED TO OPERATE THE CRANE.

Grove GMK4100B The individual crane's load chart, operating instructions and other instructional plates must be read and understood prior to operating the crane

# Working range

36 ft – 167 ft main boom with 6.6 ft heavy duty jib

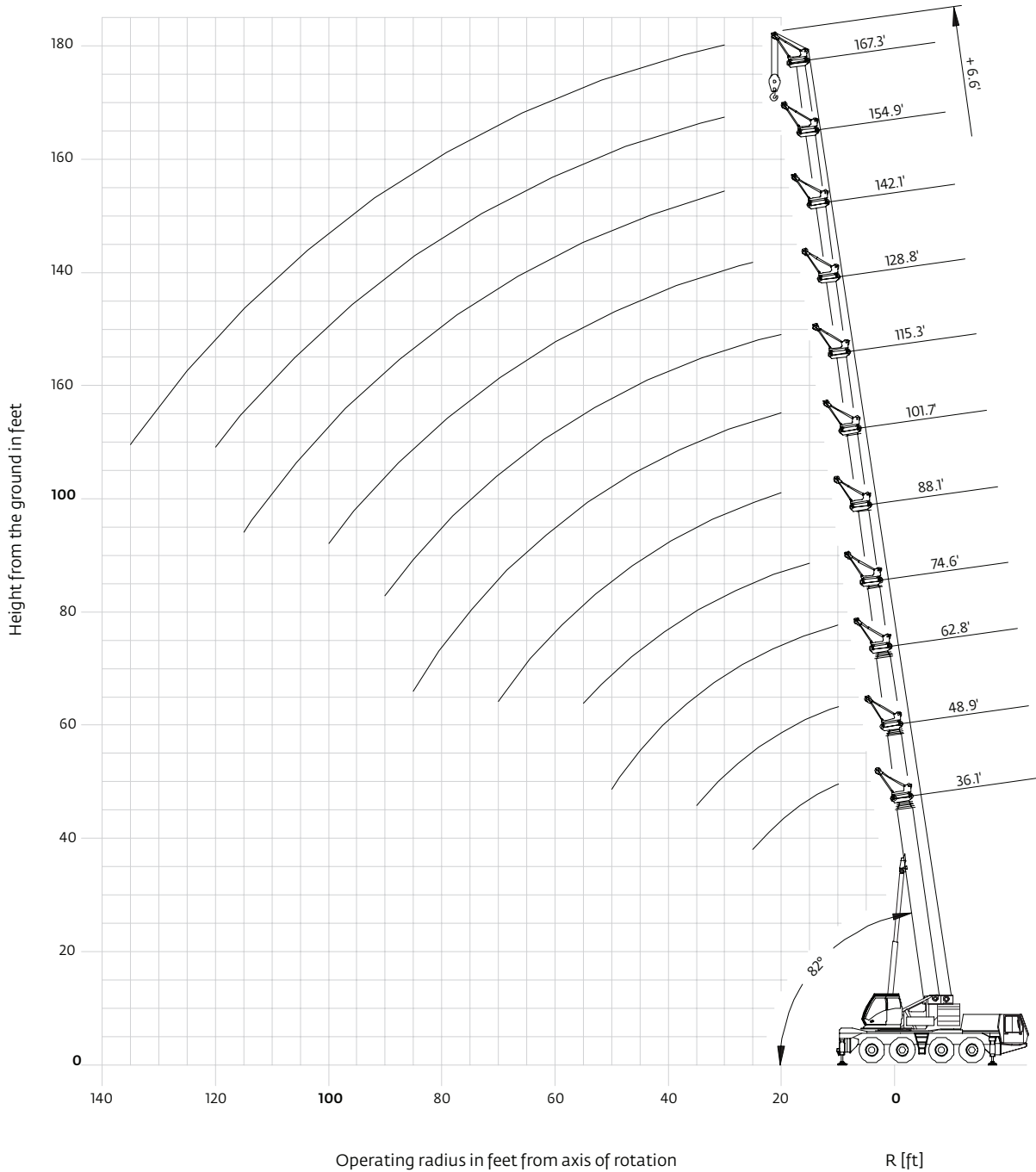

*Tip heights shown in the working range diagram do not consider loaded boom deflection.*



# Load charts

## Heavy duty jib

### Fixed angle

				
11,0 m - 51 m (36 ft - 167 ft)	2 m (6.6 ft)	19 300 kg (42,500 lb)	26.6 ft x 23.0 ft (100%)	360° 100%

Feet	36.1 ft + 6.6 ft		74.6 ft + 6.6 ft		128.8 ft + 6.6 ft		167.3 ft + 6.6 ft	
	0°	40°	0°	40°	0°	40°	0°	40°
10		22.0						
15	22.0	22.0		22.0				
20	22.0	22.0		22.0				
25	22.0	22.0		22.0		22.0		
30	22.0		22.0	22.0		22.0		12.2
35			22.0	22.0		22.0		12.2
40			22.0	22.0		22.0		12.2
45			22.0	22.0		22.0		12.2
50			22.0	22.0		22.0		12.2
55			22.0	22.0	20.6	21.0		12.2
60			22.0		18.0	18.6		12.2
65			19.4		16.0	16.4		12.2
70					14.0	14.4		12.2
75					12.4	12.8	12.8	12.2
80					11.2	11.4	11.4	11.8
85					10.4	10.4	10.2	10.6
90					9.6	9.6	9.2	9.6
95					8.8	8.8	8.4	8.6
100					8.4	8.4	7.4	7.6
105					7.8		6.8	7.0
110					7.4		6.0	6.2
115					7.0		5.4	5.4
120							4.6	4.8
125							4.0	4.2
130							3.6	3.6
135							3.0	3.2
140							2.6	
145							2.2	
150							1.8	
155							1.4	
160								

### Fixed angle

				
11,0 m - 51 m (36 ft - 167 ft)	2 m (6.6 ft)	16 800 kg (37,000 lb)	26.6 ft x 23.0 ft (100%)	360° 100%

Feet	36.1 ft + 6.6 ft		74.6 ft + 6.6 ft		128.8 ft + 6.6 ft		167.3 ft + 6.6 ft	
	0°	40°	0°	40°	0°	40°	0°	40°
10		22.0						
15	22.0	22.0		22.0				
20	22.0	22.0		22.0				
25	22.0	22.0		22.0		22.0		
30	22.0		22.0	22.0		22.0		12.2
35			22.0	22.0		22.0		12.2
40			22.0	22.0		22.0		12.2
45			22.0	22.0		22.0		12.2
50			22.0	22.0		22.0		12.2
55			22.0	22.0	19.0	19.4		12.2
60			20.4		16.6	17.0		12.2
65			18.0		14.6	15.0		12.2
70					12.8	13.2		12.2
75					12.0	11.8	11.6	12.0
80					11.2	11.2	10.4	10.6
85					10.4	10.4	9.2	9.6
90					9.6	9.6	8.2	8.6
95					8.8	8.8	7.4	7.6
100					8.4	8.4	6.6	6.8
105					7.6		5.8	6.0
110					7.0		5.2	5.4
115					6.2		4.6	4.8
120							4.0	4.2
125							3.4	3.6
130							2.8	3.0
135							2.4	2.6
140							2.0	
145							1.6	
150								

# Symbols glossary



Axles



Counterweight



Grade



Outriggers



Boom



Drive



Heavy duty jib



Radius



Boom elevation



Electrical system



Hoist



Rotation



Boom extension



Engine



Hookblock



Speed



Boom length



Extension



Hydraulic system



Steering



Boom nose



Frame



Lights



Suspension



Brakes



Fuel tank capacity



Oil



Swing



Cab



Gear



Outrigger controls



Tires



Transmission



## Regional headquarters

### Manitowoc - Americas

**Manitowoc, Wisconsin, USA**

Tel: +1 920 684 6621

Fax: +1 920 683 6277

**Shady Grove, Pennsylvania, USA**

Tel: +1 717 597 8121

Fax: +1 717 597 4062

### Manitowoc - Europe, Middle East, Africa

**Ecully, France**

Tel: +33 (0)4 72 18 20 20

Fax: +33 (0)4 72 18 20 00

### Manitowoc - Asia Pacific

**Shanghai, China**

Tel: +86 21 6457 0066

Fax: +86 21 6457 4955

## Regional offices

### Americas

**Brazil**

Alphaville

**Mexico**

Monterrey

**Chile**

Santiago

### Europe, Middle East, Africa

**Czech Republic**

Netvorice

**France**

Baudemont

Cergy

Decines

**Germany**

Langenfeld

**Hungary**

Budapest

**Italy**

Lainate

**Netherlands**

Breda

**Poland**

Warsaw

**Portugal**

Baltar

**Russia**

Moscow

**U.A.E.**

Dubai

**U.K.**

Buckingham

### Asia - Pacific

**Australia**

Brisbane

Melbourne

Sydney

**China**

Beijing

Chengdu

Guangzhou

**India**

Delhi

Hyderabad

Pune

**Korea**

Seoul

**Philippines**

Makati City

**Singapore**

## Factories

**Brazil**

Alphaville

**China**

TaiAn

Zhangjiagang

**France**

Charlieu

La Clayette

Moulins

**Germany**

Wilhelmshaven

**India**

Pune

**Italy**

Niella Tanaro

**Portugal**

Baltar

Fânzeres

**Slovakia**

Saris

**USA**

Manitowoc

Port Washington

Shady Grove

This document is non-contractual. Constant improvement and engineering progress make it necessary that we reserve the right to make specification, equipment, and price changes without notice. Illustrations shown may include optional equipment and accessories and may not include all standard equipment.