

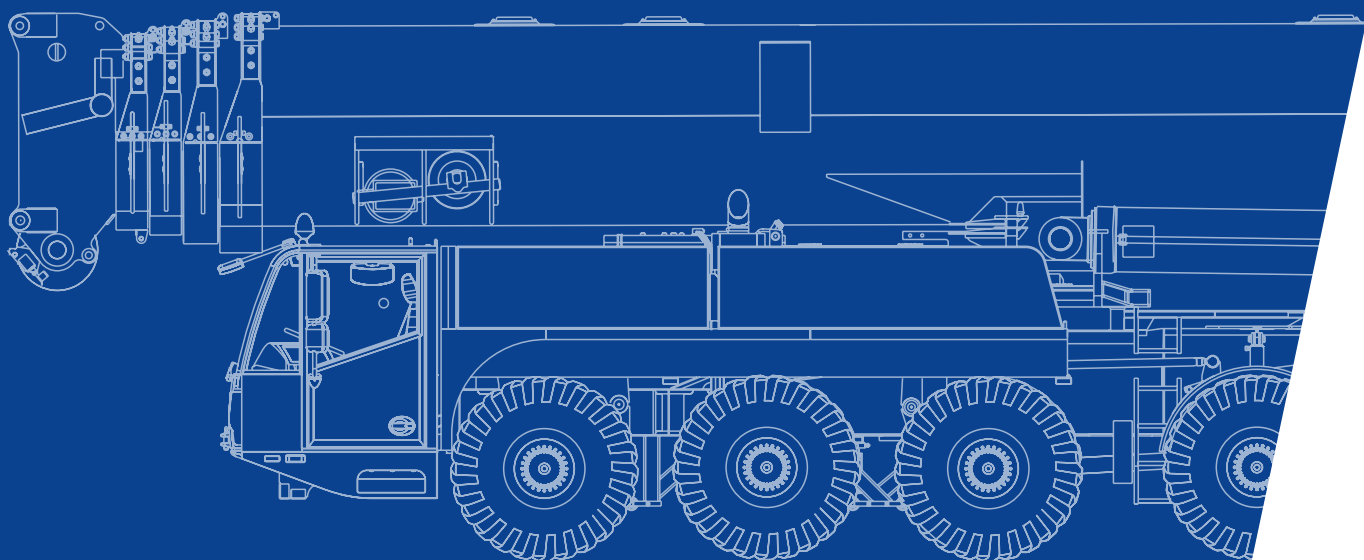

AC 700-9

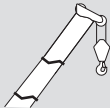

**All Terrain Crane
800 USt Capacity class**

		Page:
Dimensions		4
Specifications.....		6
Counterweight		7
Equipment.....		8
Boom combinations.....		12
	HA	
	Main boom	14
	HA-SSL	
Main boom with SSL	18	
	HAV	
	Folding swing-away jib	20
	HAV-SSL	
Folding swing-away jib with SSL	22	
	LF	
	Light fixed jib	24
	LF-SSL	
Light fixed jib with SSL.....	28	
	WIHI	
	Luffing fly jib	32
	WIHI-SSL	
Luffing fly jib with SSL	42	
Technical description.....		52

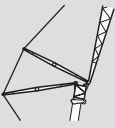
	Counterweight		Slewing
	Lifting capacities on outriggers · 360°		Working speeds
	Radius		Max. line pull
	Main boom		Rope diameter
	Folding swing-away jib		Rope length
	Fixed fly jib		Hook block (capacity-sheaves-rope diameter)
	Luffing fly jib		Number of lines
	Boom telescoping		Possible load of hook block
	Boom elevation		Weight of hook block
	Adapter		Distance head sheave axle – hook ground
	Max. axle loads		Number of sheaves in boom head
	Mechanism		Front outrigger
	Tires		Rear outrigger
	Hook block		Supporting force
	Hoist		Length of stroke (support cylinders)
	Sideways Superlift		Payload incl. rear storage box
	Travel speed		
	Gradeability – road		
	Gradeability – off road		

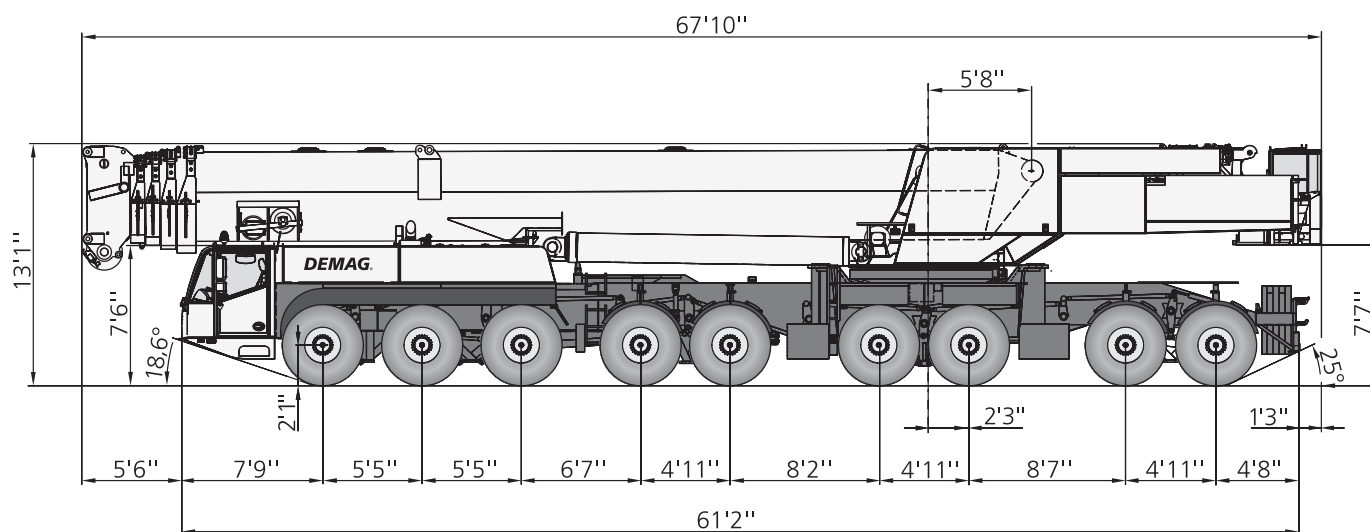

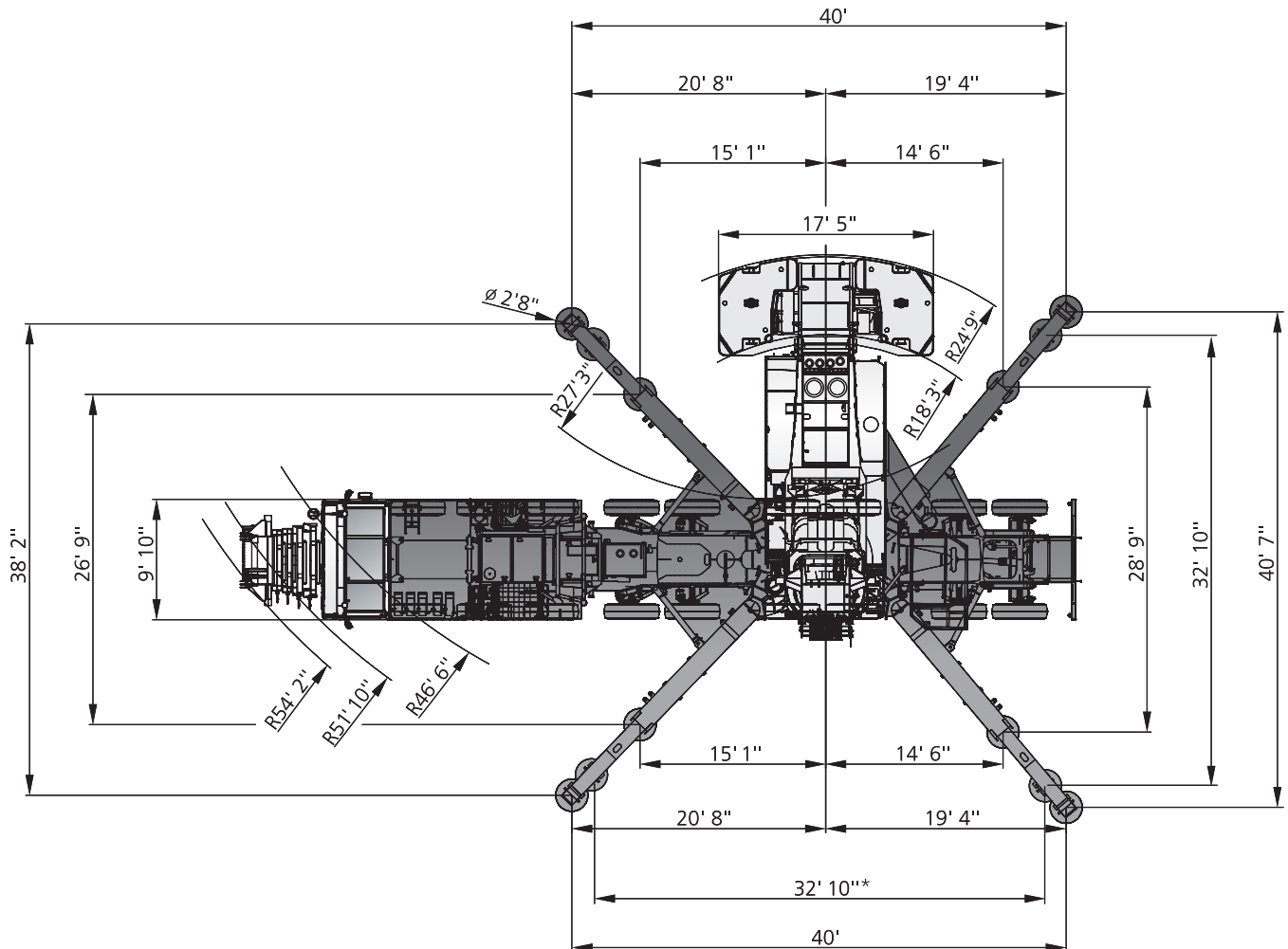









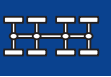

Loads with reduced outrigger base on request



* on request!

Specifications



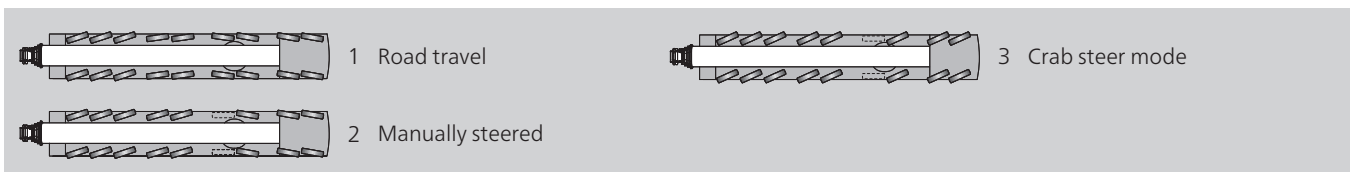

AC 700-9









		Total								
18,740 lb	136,700 lb	18x8x16	385/95R25	-	-	-	-	-	-	-
26,500 lb	238,100 lb	18x8x16	385/95R25	-	X	-	-	-	-	10,360 lb
30,210 lb	271,200 lb	18x8x16	385/95R25	40-1-26	X	X	X	-	-	-
32,000 lb	275,600 lb	18x8x16	385/95R25	40-1-26	X	-	X	X	X	-
34,180 lb	306,500 lb	18x8x16	385/95R25	40-1-26	X	X	X	X	X	10,360 lb









	
408,000 lb	408,000 lb
21.7"	21.7"
46.6 mph ¹⁾	

¹⁾ Depending on tire type, size and country specific legislation

	
	385 / 95 R25 14.00 R25
	35 %
	40 %

				
1	446.2 ft/min	30,350 lbf	1.02"	1805 ft
2	492.1 ft/min	30,350 lbf	1.02"	2526 ft
	0,7 min ⁻¹			
	ca. 480 s (50.9-196.9ft)			
	ca. 120 s (-5° - +83°)			

					
1	30,000 lb	15-0-26	9	1,980 lb	6.6 ft
2	59,540 lb	40-1-26	9	2,650 lb	8.9 ft
3	88,860 lb	40-1-26	9	2,650 lb	8.9 ft
4	118,000 lb	100-3-26	9	3,970 lb	9.8 ft
5	146,600 lb	100-3-26	9	3,970 lb	9.8 ft
6	175,100 lb	100-3-26	9	3,970 lb	9.8 ft
7	203,300 lb	100-3-26	9	3,970 lb	9.8 ft
8	231,100 lb	160-5-26	9	4,850 lb	9.8 ft
9	258,700 lb	160-5-26	9	4,850 lb	9.8 ft
10	286,000 lb	160-5-26	9	4,850 lb	9.8 ft
11	313,100 lb	160-5-26	9	4,850 lb	9.8 ft
12	339,800 lb	200-7-26	9	5,730 lb	9.8 ft
13	366,300 lb	200-7-26	9	5,730 lb	9.8 ft
14	392,700 lb	200-7-26	9	5,730 lb	9.8 ft
15	418,500 lb	200-7-26	9	5,730 lb	9.8 ft
16	444,300 lb	250-9-26	9	6,170 lb	14.8 ft
17	469,900 lb	250-9-26	9	6,170 lb	14.8 ft
18	495,000 lb	250-9-26	9	6,170 lb	14.8 ft
19	520,000 lb	250-9-26	9 + 4	6,170 lb	14.8 ft
20	544,600 lb	320-11-26	9 + 4	7,720 lb	14.8 ft
21	569,100 lb	320-11-26	9 + 4	7,720 lb	14.8 ft
22	593,400 lb	320-11-26	9 + 4	7,720 lb	14.8 ft
23	617,400 lb	320-11-26	9 + 4	7,720 lb	14.8 ft
24	641,000 lb	320-13-26	9 + 4	8,820 lb	14.8 ft
25	664,600 lb	320-13-26	9 + 4	8,820 lb	14.8 ft
26	688,000 lb	320-13-26	9 + 4	8,820 lb	14.8 ft

Counterweight

AC 700-9

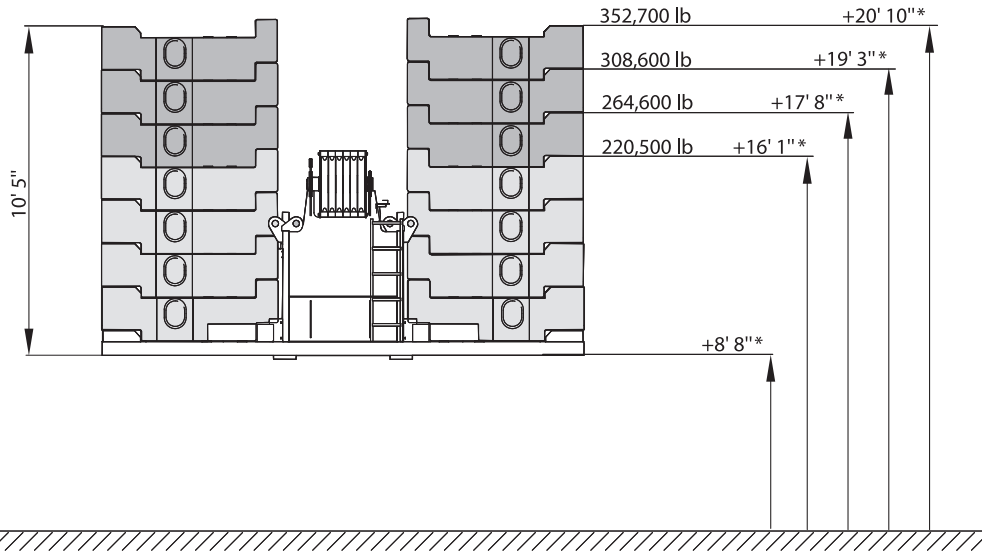

* Tail swing above ground

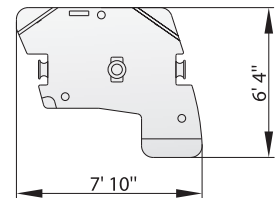
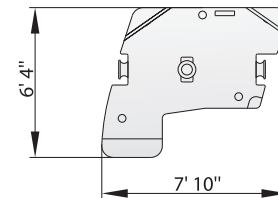
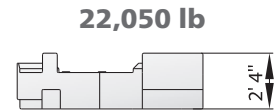
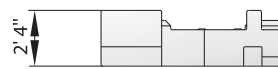
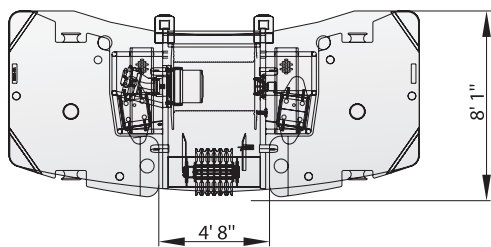
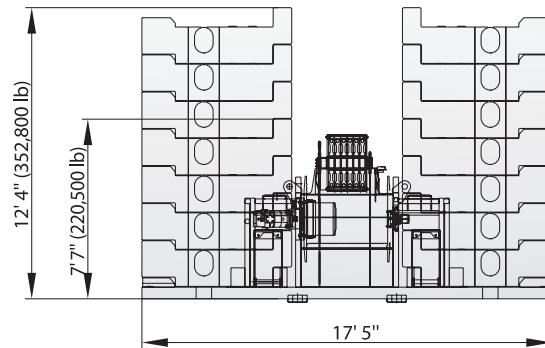

44,100 lb

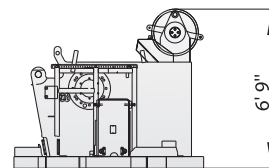
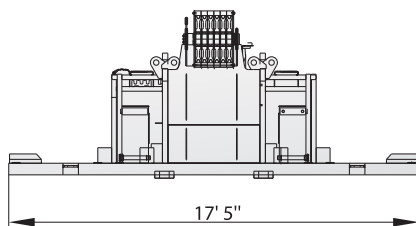

Superstructure with luffing cylinder

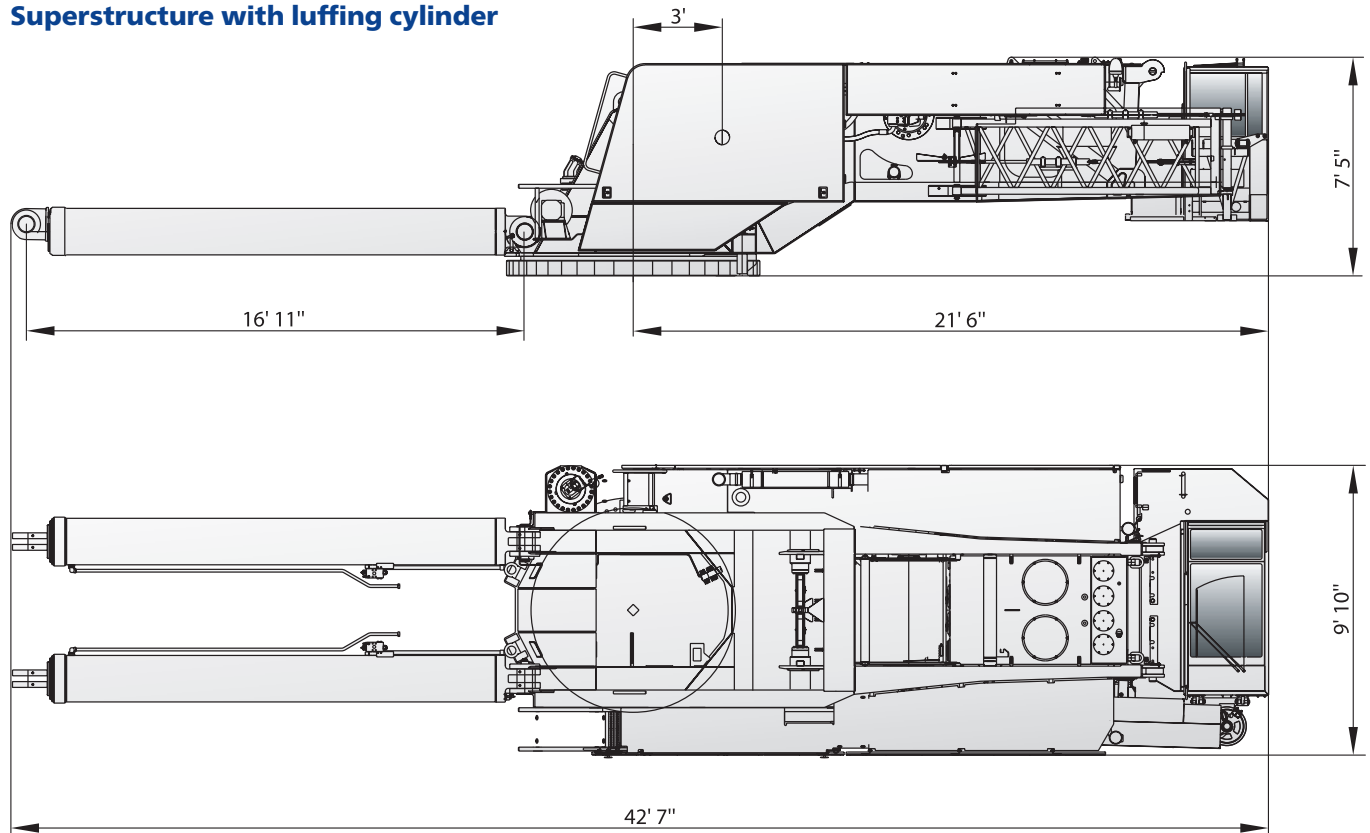

* incl. luffing cylinder

Main boom

92,600 lb

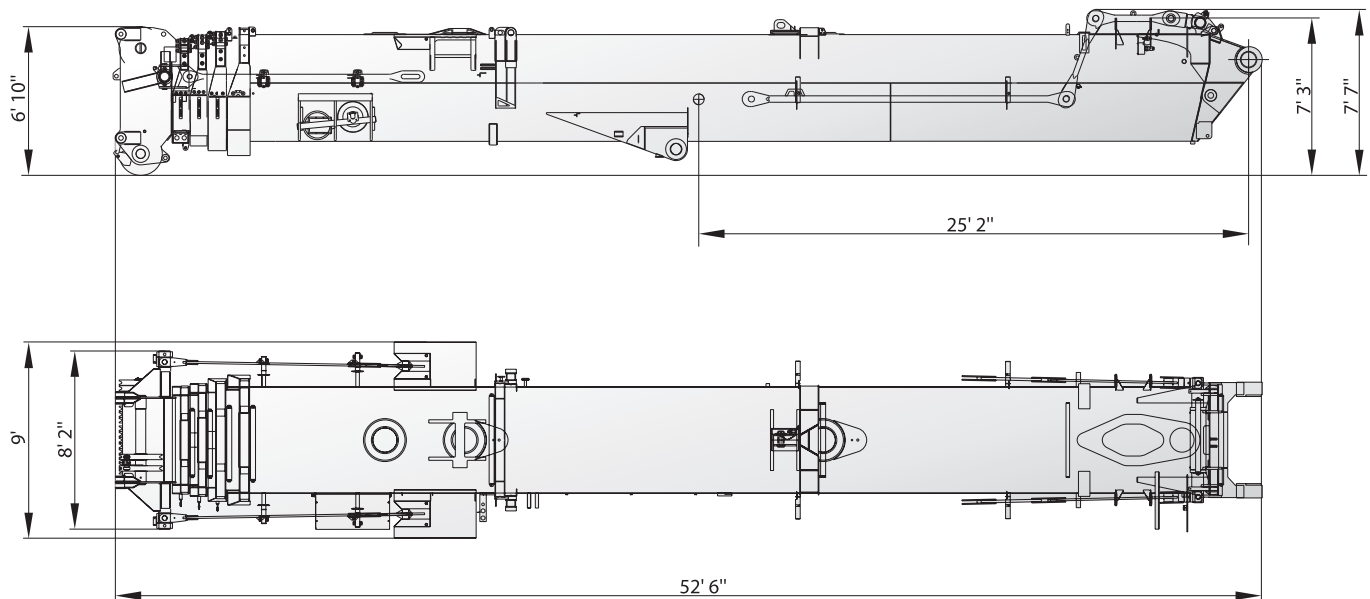

Sideways Superlift SSL

26,500 lb

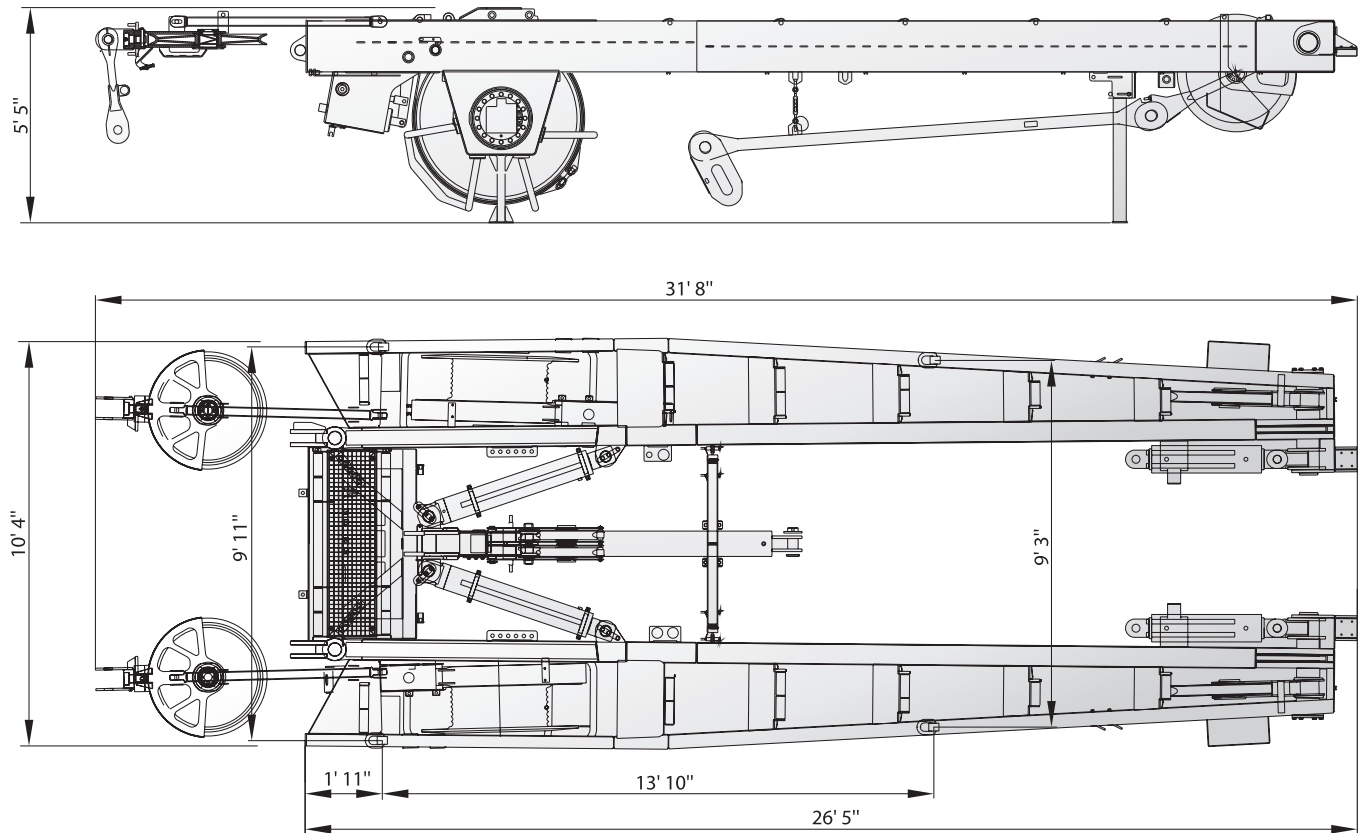

Outriggers

10,580 lb

10,580 lb

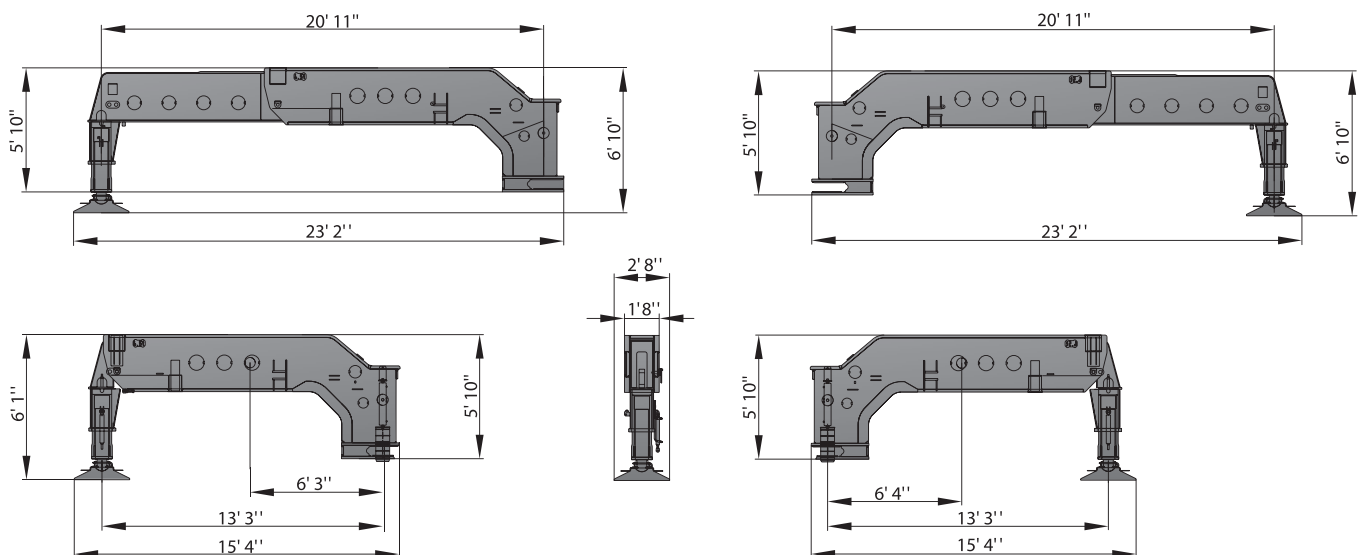

LF

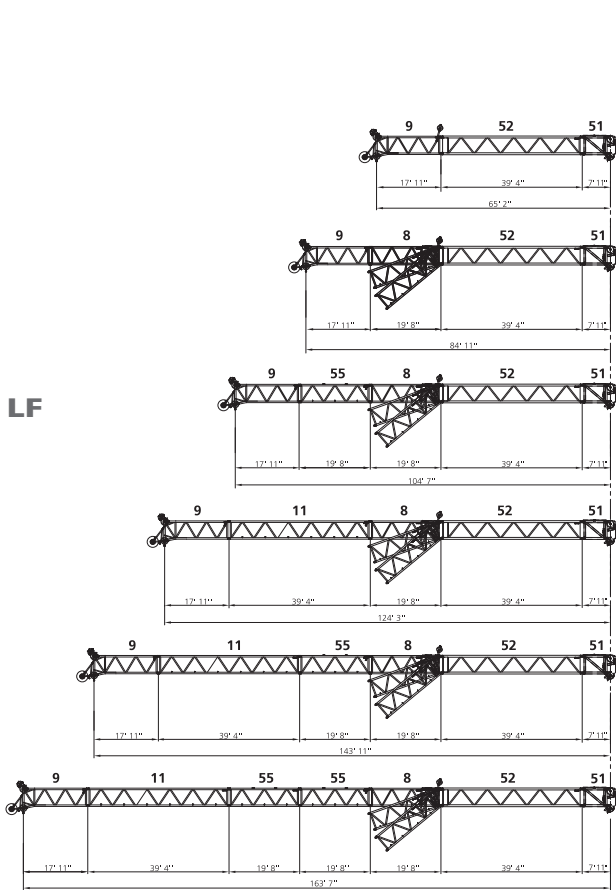

HAV

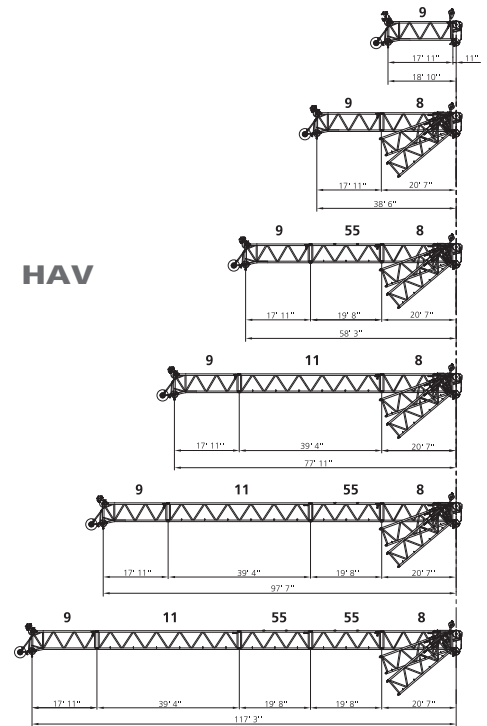

WIHI

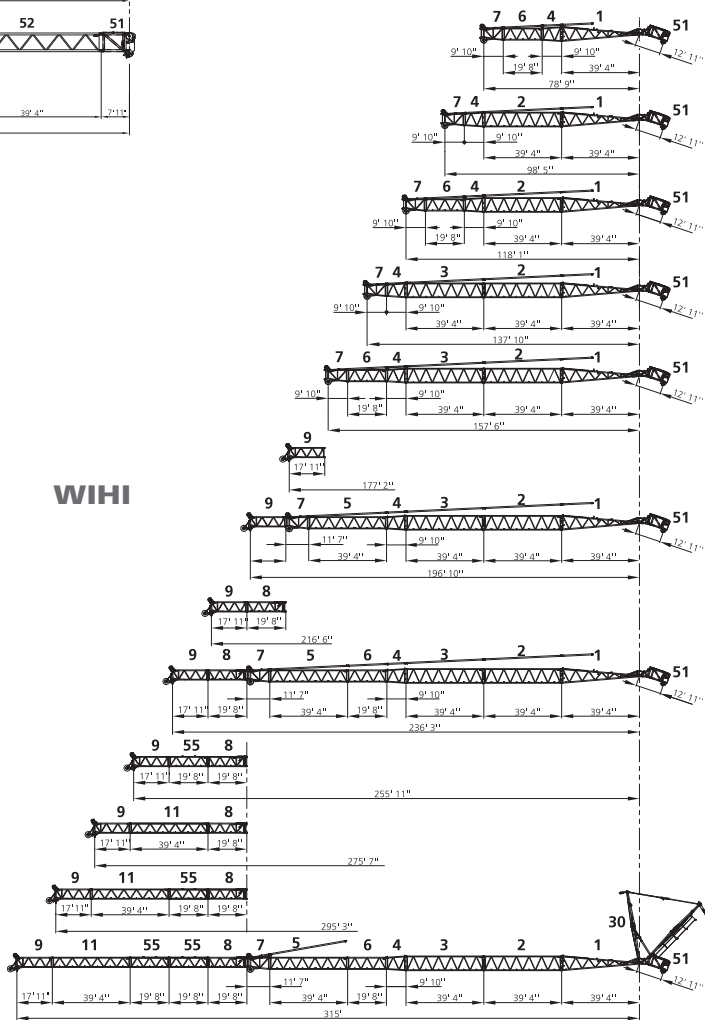

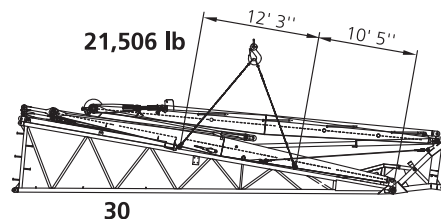
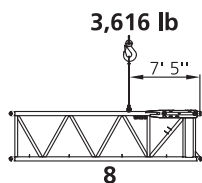
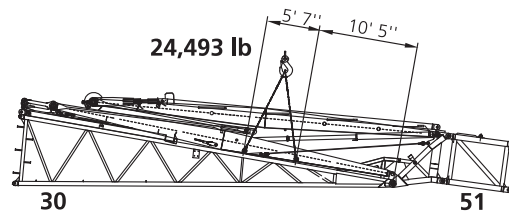
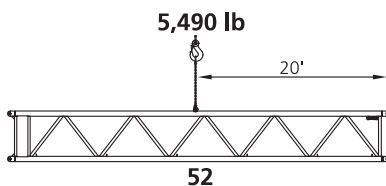
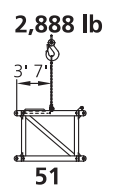
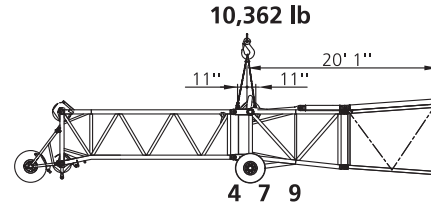
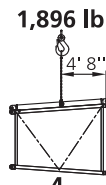
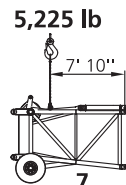
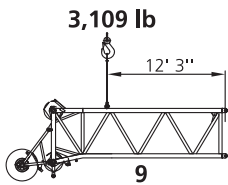
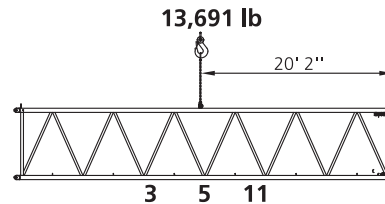
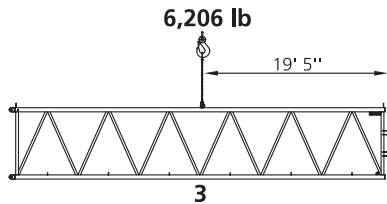
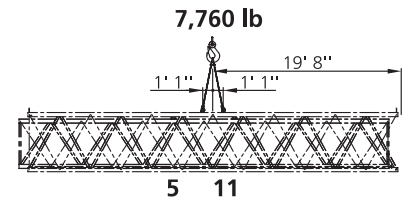
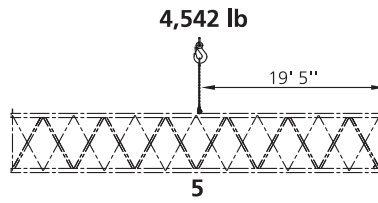
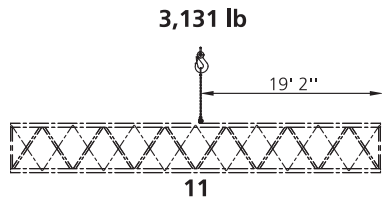
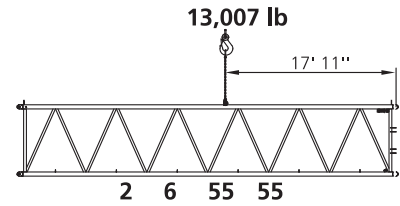
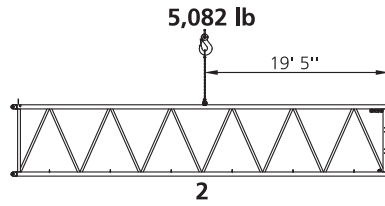
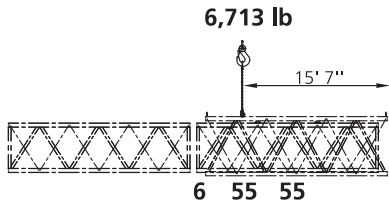
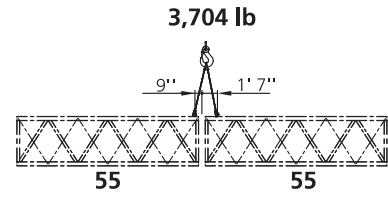
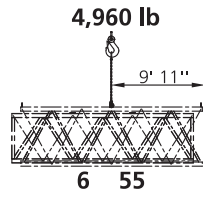
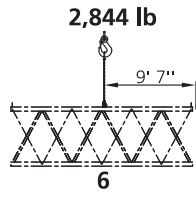
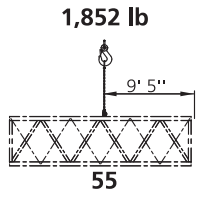

Boom Combinations

AC 700-9

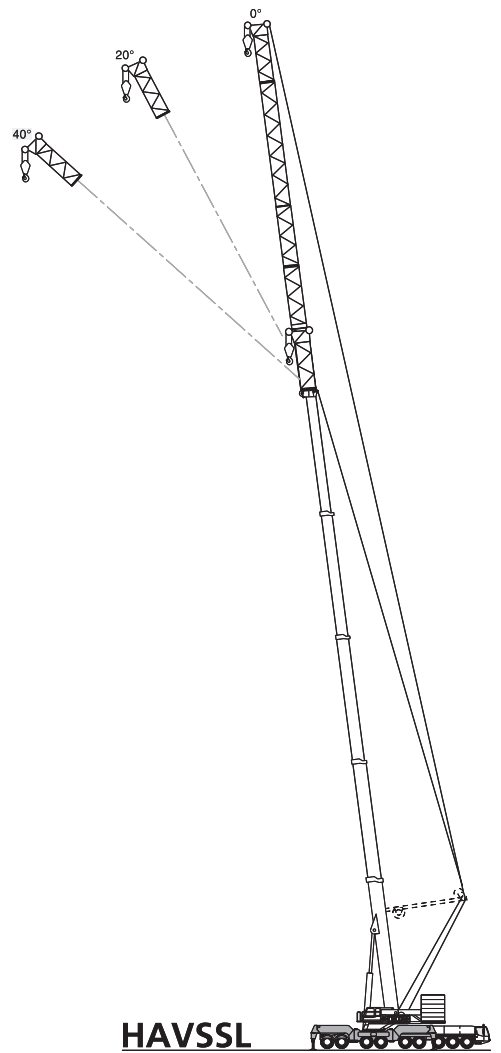
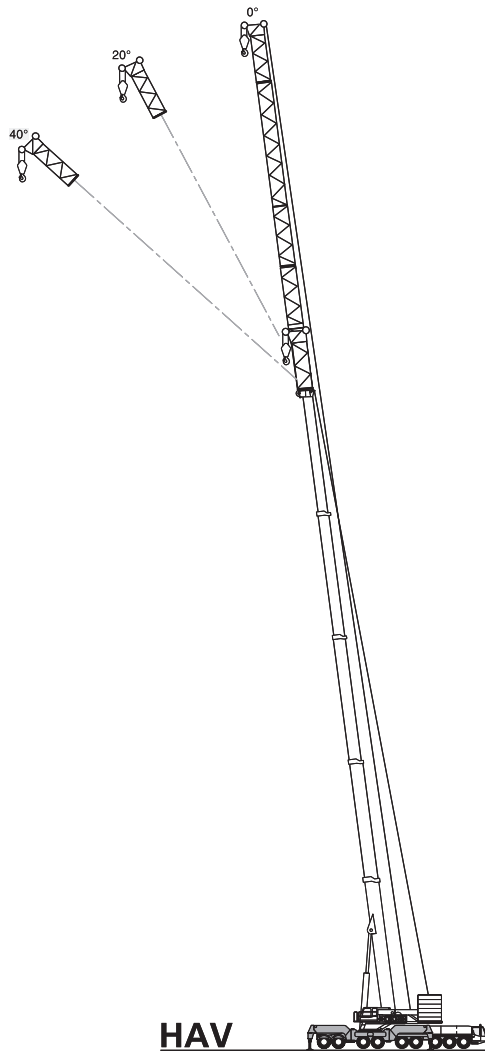
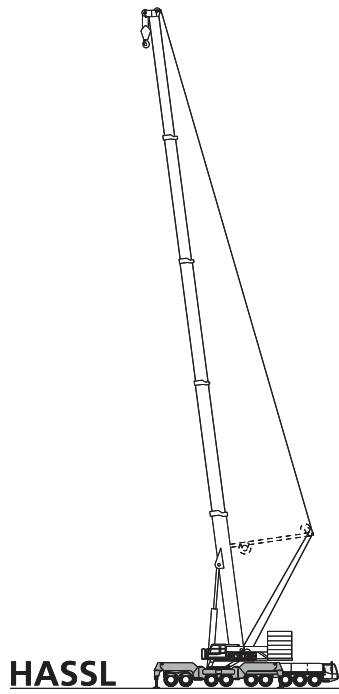
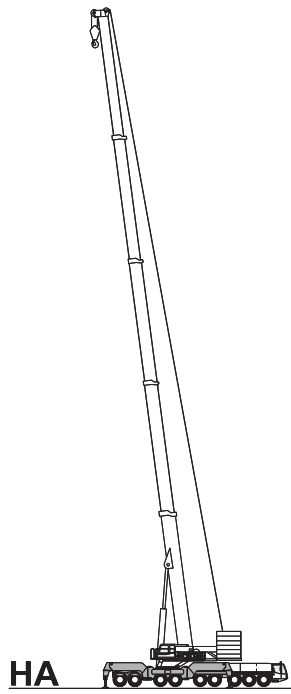

Boom Combinations

AC 700-9

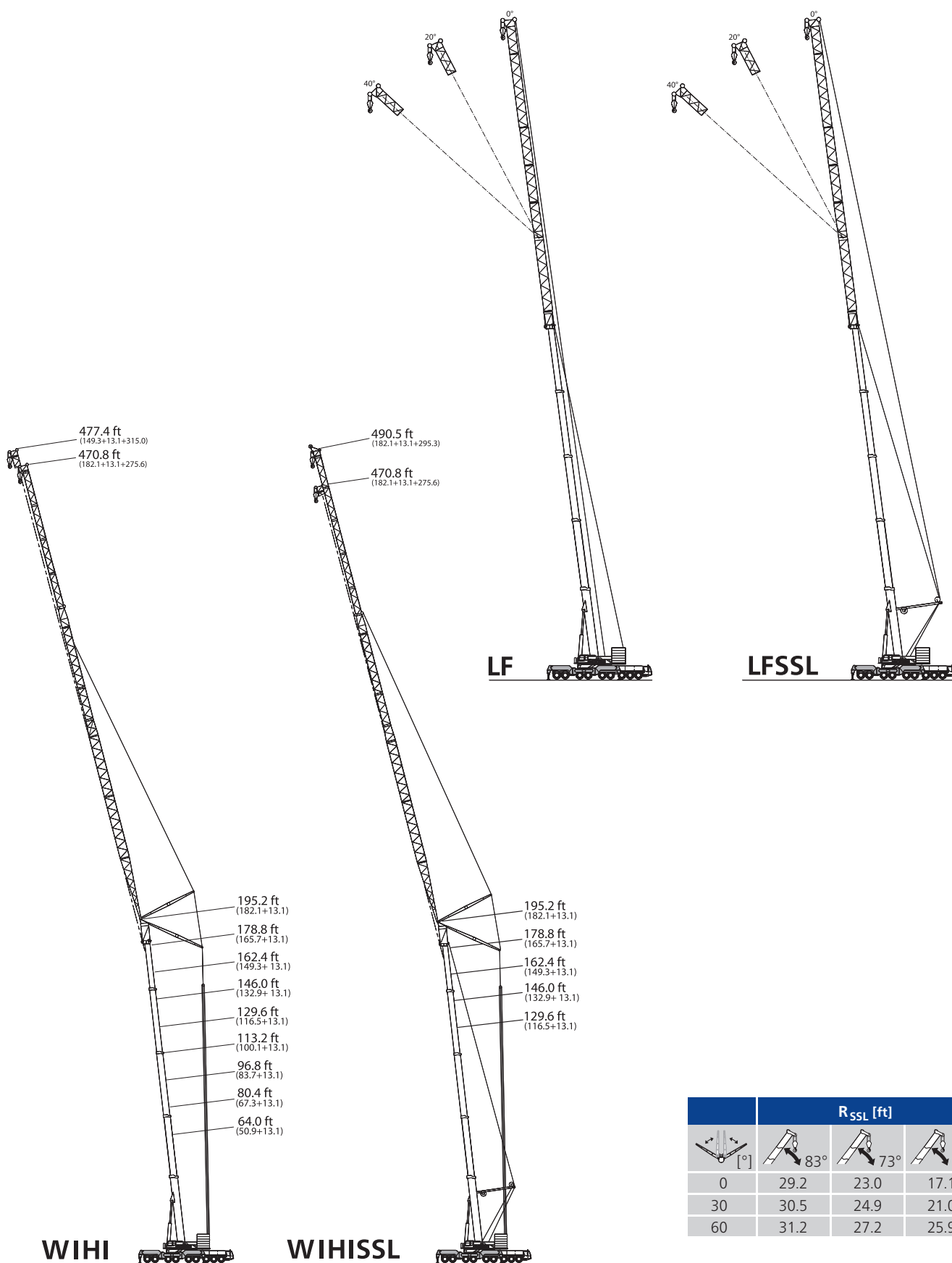

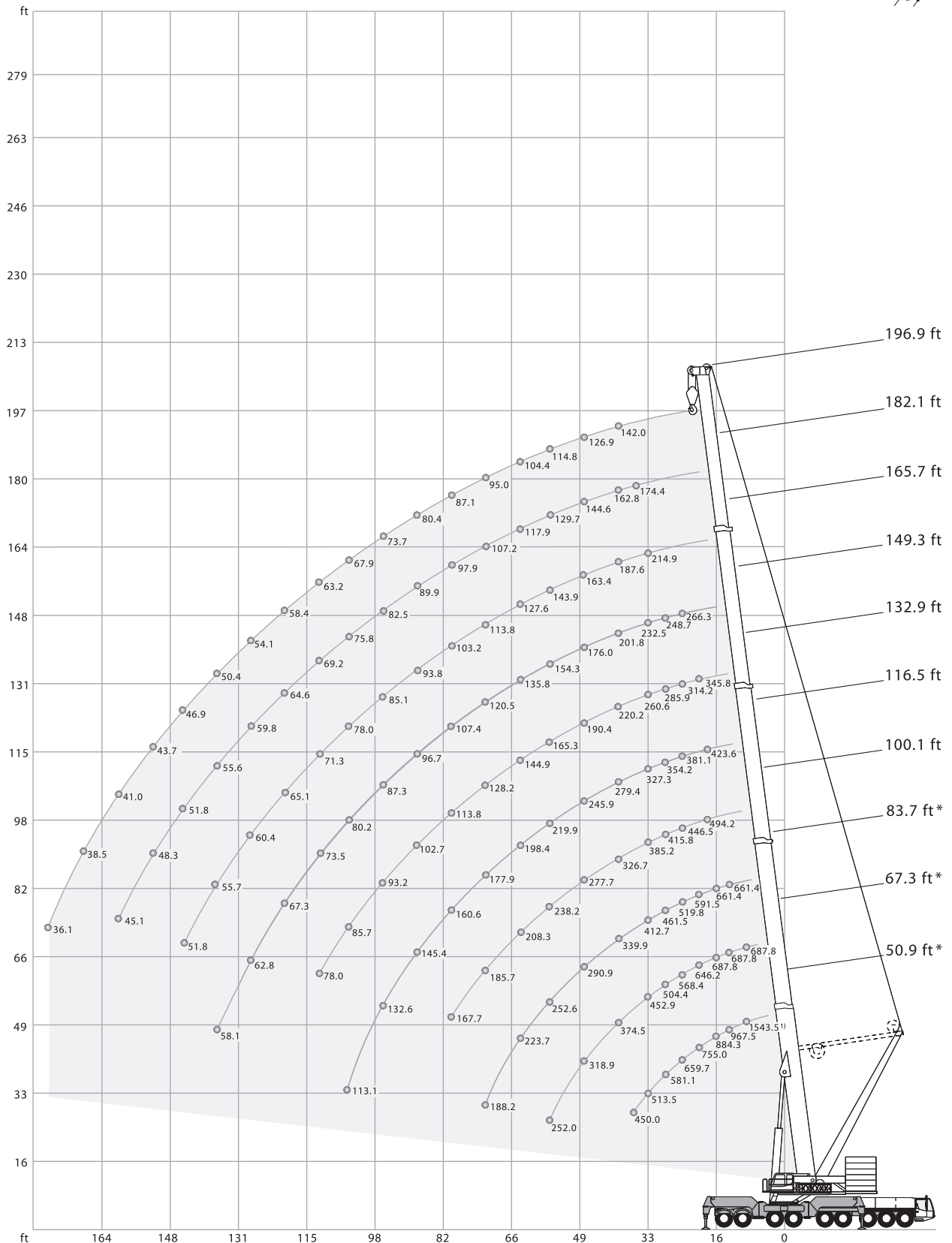
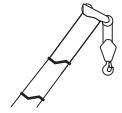

For explanations see page 15

☰ 308,600 lb		📐 360°												85%	
📐		50.9 ft*	50.9 ft	67.3 ft*	67.3 ft	83.7 ft*	83.7 ft	100.1 ft	116.5 ft	132.9 ft	149.3 ft	165.7 ft	182.1 ft	196.9 ft	📐
ft	1,000 lb														ft
8	1543.5 ¹⁾	-	-	-	-	-	-	-	-	-	-	-	-	-	8
10	1255.1 ²⁾	687.8	687.8	687.8	-	-	-	-	-	-	-	-	-	-	10
12	1067.8 ²⁾	687.8	687.8	687.8	-	-	-	-	-	-	-	-	-	-	12
14	967.5 ²⁾	687.8	687.8	687.8	661.4	661.4	-	-	-	-	-	-	-	-	14
16	884.3 ²⁾	674.5	687.8	672.9	661.4	661.4	-	-	-	-	-	-	-	-	16
18	817.2 ²⁾	635.9	670.7	633.7	630.3	630.3	494.2	423.6	-	-	-	-	-	-	18
20	755.0 ²⁾	594.4	646.2	592.0	591.5	591.5	478.1	409.9	345.8	-	-	-	-	-	20
24	659.7	529.3	568.4	525.5	519.8	519.8	446.5	381.1	314.2	266.3	-	-	-	-	24
28	581.1	473.7	504.4	471.5	461.5	461.5	415.8	354.2	285.9	248.7	-	-	-	-	28
32	513.5	429.2	452.9	425.4	412.7	412.7	385.2	327.3	260.6	232.5	214.9	-	-	-	32
36	450.0	393.2	412.0	388.8	374.5	374.5	355.6	302.6	239.6	216.9	200.9	174.4	-	-	36
40	-	-	374.5	355.1	339.9	339.9	326.7	279.4	220.2	201.8	187.6	162.8	142.0	40	
48	-	-	318.9	303.5	290.9	290.9	277.7	245.9	190.4	176.0	163.4	144.6	126.9	48	
56	-	-	252.0	239.5	252.6	252.6	238.2	219.9	165.3	154.3	143.9	129.7	114.8	56	
64	-	-	-	-	223.7	223.7	208.3	198.4	144.9	135.8	127.6	117.9	104.4	64	
72	-	-	-	-	188.2	179.6	185.7	177.9	128.2	120.5	113.8	107.2	95.0	72	
80	-	-	-	-	-	-	167.7	160.6	113.8	107.4	103.2	97.9	87.1	80	
88	-	-	-	-	-	-	-	145.4	102.7	96.7	93.8	89.9	80.4	88	
96	-	-	-	-	-	-	-	132.6	93.2	87.3	85.1	82.5	73.7	96	
104	-	-	-	-	-	-	-	113.1	85.7	80.2	78.0	75.8	67.9	104	
112	-	-	-	-	-	-	-	-	78.0	73.5	71.3	69.2	63.2	112	
120	-	-	-	-	-	-	-	-	-	67.3	65.1	64.6	58.4	120	
128	-	-	-	-	-	-	-	-	-	62.8	60.4	59.8	54.1	128	
136	-	-	-	-	-	-	-	-	-	58.1	55.7	55.6	50.4	136	
144	-	-	-	-	-	-	-	-	-	-	51.8	51.8	46.9	144	
152	-	-	-	-	-	-	-	-	-	-	-	48.3	43.7	152	
160	-	-	-	-	-	-	-	-	-	-	-	45.1	41.0	160	
168	-	-	-	-	-	-	-	-	-	-	-	-	38.5	168	
176	-	-	-	-	-	-	-	-	-	-	-	-	36.1	176	

* central jack leg + 352,700 lb counterweight
 1) over rear, special attachment required, on request
 2) over rear, heavy-lift attachment required

☰ 220,500 lb		⏏ 360°										85%
↙ ↘	↙ ↘	50.9 ft	67.3 ft	83.7 ft	100.1 ft	116.5 ft	132.9 ft	149.3 ft	165.7 ft	182.1 ft	196.9 ft	↙ ↘
ft		1,000 lb										ft
10		687.8	687.8	-	-	-	-	-	-	-	-	10
12		687.8	687.8	-	-	-	-	-	-	-	-	12
14		687.8	687.8	661.4	-	-	-	-	-	-	-	14
16		661.2	659.6	654.7	-	-	-	-	-	-	-	16
18		619.4	617.1	619.4	494.2	423.6	-	-	-	-	-	18
20		578.9	576.7	578.7	478.1	409.9	345.8	-	-	-	-	20
24		514.5	511.6	512.3	446.5	381.1	314.2	266.3	-	-	-	24
28		461.6	457.2	459.4	415.8	354.2	285.9	248.7	-	-	-	28
32		416.5	413.8	412.7	385.2	327.3	260.6	232.5	214.9	-	-	32
36		381.0	377.8	374.5	355.6	302.6	239.6	216.9	200.9	174.4	-	36
40		-	343.0	339.3	326.7	279.4	220.2	201.8	187.6	162.8	142.0	40
48		-	280.0	281.5	277.7	245.9	190.4	176.0	163.4	144.6	126.9	48
56		-	227.2	233.7	237.0	219.9	165.3	154.3	143.9	129.7	114.8	56
64		-	-	191.7	196.1	197.5	144.9	135.8	127.6	117.9	104.4	64
72		-	-	156.2	159.5	163.9	128.2	120.5	113.8	107.2	95.0	72
80		-	-	-	133.5	137.7	113.8	107.4	103.2	97.9	87.1	80
88		-	-	-	-	117.6	102.7	96.7	93.8	89.9	80.4	88
96		-	-	-	-	101.5	93.2	87.3	85.1	82.5	73.7	96
104		-	-	-	-	89.5	84.8	80.2	78.0	75.8	67.9	104
112		-	-	-	-	-	75.5	73.5	71.3	69.2	63.2	112
120		-	-	-	-	-	-	66.6	65.1	64.6	58.4	120
128		-	-	-	-	-	-	59.5	60.2	59.8	54.1	128
136		-	-	-	-	-	-	53.0	54.1	55.6	50.4	136
144		-	-	-	-	-	-	-	48.3	50.7	46.9	144
152		-	-	-	-	-	-	-	-	45.5	43.7	152
160		-	-	-	-	-	-	-	-	41.0	40.8	160
168		-	-	-	-	-	-	-	-	-	37.2	168
176		-	-	-	-	-	-	-	-	-	33.4	176

☰ 132,300 lb		⚖️ 360°										85%
↙ ↘	50.9 ft	67.3 ft	83.7 ft	100.1 ft	116.5 ft	132.9 ft	149.3 ft	165.7 ft	182.1 ft	196.9 ft	↙ ↘	
ft	1,000 lb										ft	
10	687.8	687.8	-	-	-	-	-	-	-	-	10	
12	687.8	687.8	-	-	-	-	-	-	-	-	12	
14	679.6	678.4	661.4	-	-	-	-	-	-	-	14	
16	644.2	641.9	639.8	-	-	-	-	-	-	-	16	
18	602.8	600.6	600.6	494.2	423.6	-	-	-	-	-	18	
20	563.5	561.3	561.5	478.1	409.9	345.8	-	-	-	-	20	
24	499.8	496.9	499.1	446.5	381.1	314.2	266.3	-	-	-	24	
28	448.4	445.2	446.2	415.8	354.2	285.9	248.7	-	-	-	28	
32	395.0	391.1	392.8	385.2	327.3	260.6	232.5	214.9	-	-	32	
36	347.1	342.7	344.9	345.9	302.6	239.6	216.9	200.9	174.4	-	36	
40	-	298.3	300.7	305.1	279.4	220.2	201.8	187.6	162.8	142.0	40	
48	-	224.5	228.2	232.9	236.2	190.4	176.0	163.4	144.6	126.9	48	
56	-	164.6	166.8	171.7	177.2	164.7	154.3	143.9	129.7	114.8	56	
64	-	-	128.0	132.5	137.1	133.8	132.5	127.6	117.9	104.4	64	
72	-	-	101.9	105.3	109.7	106.4	107.5	109.5	107.2	95.0	72	
80	-	-	-	86.7	90.3	87.8	87.8	90.1	92.3	87.1	80	
88	-	-	-	-	75.9	73.1	73.1	74.8	77.5	78.1	88	
96	-	-	-	-	64.7	61.7	62.0	63.5	66.2	66.6	96	
104	-	-	-	-	56.0	51.9	52.3	54.1	56.7	57.3	104	
112	-	-	-	-	-	43.9	44.1	45.7	48.5	49.2	112	
120	-	-	-	-	-	-	37.4	38.9	41.8	42.2	120	
128	-	-	-	-	-	-	31.8	33.3	35.9	36.3	128	
136	-	-	-	-	-	-	27.2	28.4	30.8	31.3	136	
144	-	-	-	-	-	-	-	24.2	26.4	26.9	144	
152	-	-	-	-	-	-	-	-	22.7	23.1	152	
160	-	-	-	-	-	-	-	-	19.6	19.8	160	
168	-	-	-	-	-	-	-	-	-	17.0	168	
176	-	-	-	-	-	-	-	-	-	14.3	176	

☰ 0 lb		⚖️ 360°										85%
↙ ↘	50.9 ft	67.3 ft	83.7 ft	100.1 ft	116.5 ft	132.9 ft	149.3 ft	165.7 ft	182.1 ft	196.9 ft	↙ ↘	
ft	1,000 lb										ft	
10	687.8	687.8	-	-	-	-	-	-	-	-	10	
12	687.1	686.4	-	-	-	-	-	-	-	-	12	
14	663.3	661.1	652.0	-	-	-	-	-	-	-	14	
16	615.5	613.3	615.5	-	-	-	-	-	-	-	16	
18	569.8	567.6	569.8	494.2	423.6	-	-	-	-	-	18	
20	523.1	520.9	520.5	470.2	405.5	343.5	-	-	-	-	20	
24	425.2	406.3	378.6	340.6	314.6	274.7	248.0	-	-	-	24	
28	317.8	279.2	252.7	237.6	226.3	200.1	185.5	-	-	-	28	
32	201.7	188.2	183.6	176.8	172.4	153.6	144.0	137.7	-	-	32	
36	144.9	136.0	137.6	138.0	139.0	124.6	117.4	112.9	111.2	-	36	
40	-	94.8	98.0	104.4	109.9	99.7	94.6	91.5	91.5	87.3	40	
48	-	56.9	59.1	63.9	69.3	66.0	65.5	65.3	65.7	63.6	48	
56	-	36.0	37.4	41.8	46.9	43.7	44.4	46.3	48.4	46.9	56	
64	-	-	23.9	27.8	32.3	29.4	29.9	31.9	34.6	34.6	64	
72	-	-	13.7	17.8	22.3	19.4	20.0	21.8	24.5	25.1	72	
80	-	-	-	10.0	14.8	11.1	11.7	13.9	17.0	17.7	80	
88	-	-	-	-	8.5	-	-	7.4	10.4	11.3	88	
96	-	-	-	-	-	-	-	-	-	6.1	96	

☰ 352,700 lb		⌒ 360°						85%
↙	↘	116.5 ft	132.9 ft	149.3 ft	165.7 ft	182.1 ft	196.9 ft	↙
ft		1,000 lb						ft
18		429.9	-	-	-	-	-	18
20		429.3	360.7	-	-	-	-	20
24		421.2	350.7	303.7	-	-	-	24
28		410.8	342.6	294.1	250.1	-	-	28
32		394.0	332.9	287.7	247.5	204.7	158.2	32
36		370.9	322.1	281.2	243.7	200.7	155.5	36
40		346.7	310.9	274.7	239.5	196.6	152.7	40
48		299.7	283.4	263.3	229.4	186.8	145.6	48
56		259.1	253.8	242.8	220.2	176.1	137.6	56
64		226.4	225.1	218.2	206.1	165.3	129.5	64
72		201.2	201.1	197.8	190.0	155.6	122.5	72
80		179.4	181.1	180.2	174.0	146.2	115.8	80
88		157.4	161.9	163.2	159.3	136.8	109.5	88
96		133.8	143.8	147.1	145.2	128.1	104.1	96
104		102.3	127.7	131.9	132.7	120.0	98.8	104
112		-	107.8	118.4	120.6	112.0	94.5	112
120		-	-	105.6	110.2	103.9	89.4	120
128		-	-	89.7	101.4	96.4	85.4	128
136		-	-	-	90.1	90.0	81.7	136
144		-	-	-	76.7	84.0	78.4	144
152		-	-	-	-	77.0	74.4	152
160		-	-	-	-	66.5	70.4	160
168		-	-	-	-	-	63.8	168
176		-	-	-	-	-	54.7	176

☰ 264,600 lb		⌒ 360°						85%
↙	↘	116.5 ft	132.9 ft	149.3 ft	165.7 ft	182.1 ft	196.9 ft	↙
ft		1,000 lb						ft
18		429.9	-	-	-	-	-	18
20		429.3	360.7	-	-	-	-	20
24		421.2	350.7	303.7	-	-	-	24
28		410.8	342.6	294.1	250.1	-	-	28
32		394.0	332.9	287.7	247.5	204.7	158.2	32
36		368.8	322.1	281.2	243.7	200.7	155.5	36
40		341.9	310.9	274.7	239.5	196.6	152.7	40
48		290.9	283.4	263.3	229.4	186.8	145.6	48
56		247.9	249.1	242.8	220.2	176.1	137.6	56
64		209.9	212.9	214.9	206.1	165.3	129.5	64
72		179.2	183.6	186.9	190.0	155.6	122.5	72
80		154.7	159.1	162.4	165.9	146.2	115.8	80
88		131.0	134.9	138.3	142.7	136.8	109.5	88
96		112.2	115.5	118.8	123.2	125.3	104.1	96
104		97.6	100.9	103.2	107.6	111.0	98.8	104
112		-	87.7	90.9	94.2	97.5	94.5	112
120		-	-	80.5	83.8	87.1	88.2	120
128		-	-	71.6	74.9	78.2	78.8	128
136		-	-	-	67.2	70.2	70.7	136
144		-	-	-	60.7	63.5	64.2	144
152		-	-	-	-	57.4	58.3	152
160		-	-	-	-	52.0	52.6	160
168		-	-	-	-	-	47.8	168
176		-	-	-	-	-	43.2	176

☰ 220,500 lb		☰ 360°						85%
ft	116.5 ft	132.9 ft	149.3 ft	165.7 ft	182.1 ft	196.9 ft	ft	
1,000 lb								
18	429.9	-	-	-	-	-	18	
20	429.3	360.7	-	-	-	-	20	
24	421.2	350.7	303.7	-	-	-	24	
28	410.8	342.6	294.1	250.1	-	-	28	
32	394.0	332.9	287.7	247.5	204.7	158.2	32	
36	366.6	322.1	281.2	243.7	200.7	155.5	36	
40	337.1	310.9	274.7	239.5	196.6	152.7	40	
48	279.3	279.2	263.3	229.4	186.8	145.6	48	
56	231.4	235.3	238.1	220.2	176.1	137.6	56	
64	192.8	196.9	201.1	199.4	165.3	129.5	64	
72	156.2	160.6	165.0	169.3	155.6	122.5	72	
80	128.9	133.3	136.6	141.9	144.3	115.8	80	
88	108.8	112.7	116.0	120.4	123.7	109.5	88	
96	92.7	96.0	99.3	103.0	106.3	104.1	96	
104	78.8	82.1	85.4	89.7	92.0	93.2	104	
112	-	71.1	74.4	77.7	81.0	82.1	112	
120	-	-	65.2	68.7	72.0	72.7	120	
128	-	-	57.1	61.0	64.1	64.6	128	
136	-	-	-	53.8	57.1	58.0	136	
144	-	-	-	47.7	50.8	51.4	144	
152	-	-	-	-	45.2	46.0	152	
160	-	-	-	-	40.4	41.1	160	
168	-	-	-	-	-	36.9	168	
176	-	-	-	-	-	33.0	176	

HAV, HAV-SSL 0°

AC 700-9

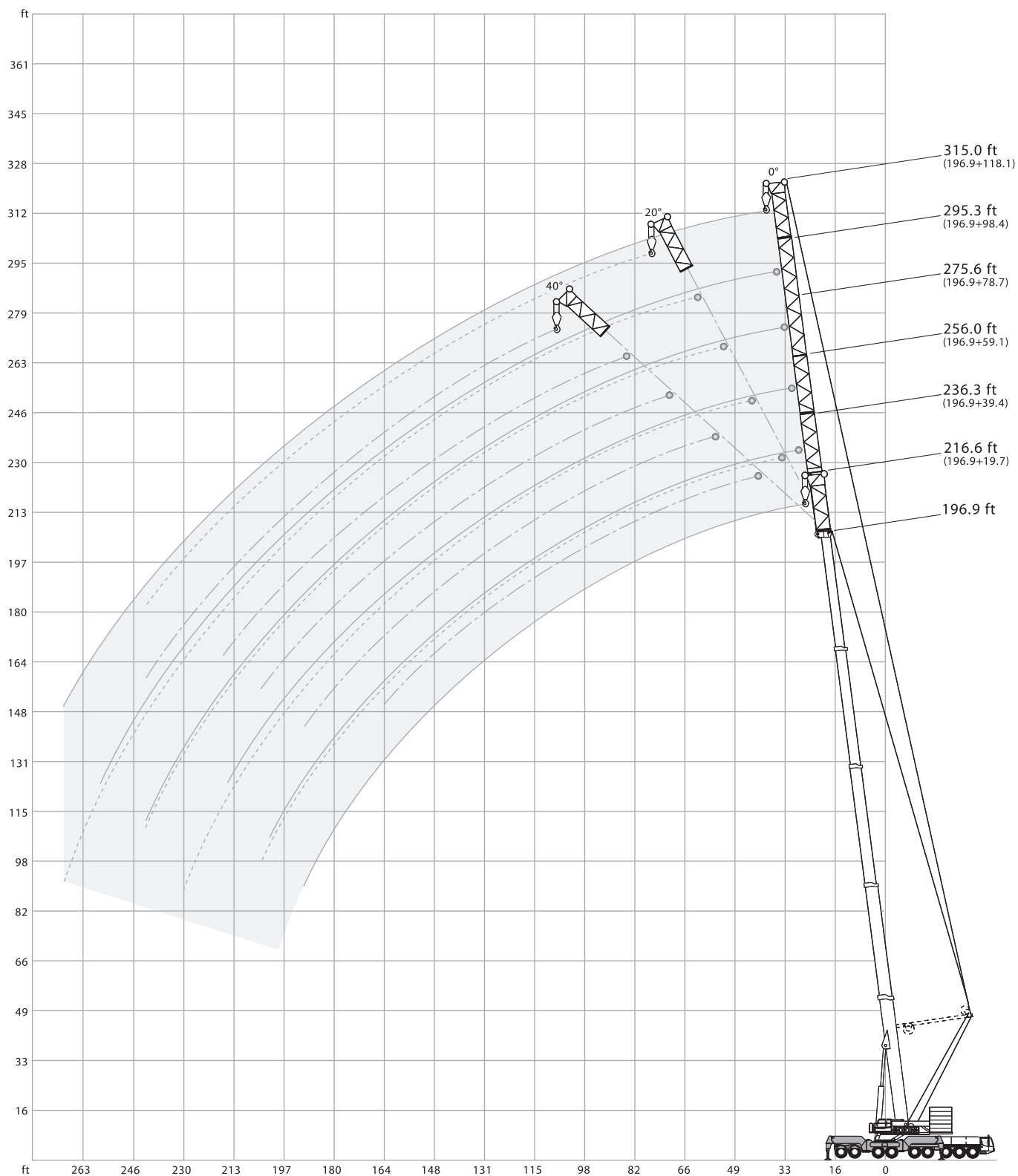

220,500 lb													360°		85%	
196.9 ft																
ft	19.7 ft	39.4 ft		59.1 ft		78.7 ft		98.4 ft		118.1 ft		ft				
		0°	0°	20°	0°	20°	0°	20°	0°	20°	0°		20°			
1,000 lb																
48	99.9	-	-	-	-	-	-	-	-	-	-	48	-	-		
56	91.1	78.5	-	66.8	-	-	-	-	-	-	-	56	-	-		
64	83.3	71.6	62.7	61.6	-	50.6	-	41.9	-	-	-	64	-	-		
72	76.2	65.6	58.9	57.0	-	47.3	-	39.9	-	33.3	-	72	-	-		
80	70.1	60.6	55.5	53.0	45.4	44.3	-	38.1	-	31.7	-	80	-	-		
88	64.5	56.2	52.4	49.3	43.1	41.6	33.1	36.2	-	29.9	-	88	-	-		
96	59.6	52.4	49.5	46.1	40.8	39.1	31.9	34.3	27.8	28.3	-	96	-	-		
104	55.2	49.1	46.6	43.3	38.8	36.9	30.8	32.4	26.6	26.7	-	104	-	-		
112	51.2	45.9	44.0	40.6	36.9	34.7	29.7	30.8	25.3	25.1	20.5	112	-	-		
120	47.6	43.2	41.5	38.2	35.1	32.8	28.6	28.9	24.2	23.6	19.6	120	-	-		
128	44.2	40.4	39.2	35.9	33.5	30.9	27.7	27.2	22.9	22.1	18.6	128	-	-		
136	41.1	37.9	37.1	33.8	31.9	29.1	26.7	25.5	21.7	20.8	17.7	136	-	-		
144	38.3	35.4	34.9	31.8	30.5	27.4	25.6	23.9	20.3	19.5	16.8	144	-	-		
152	35.8	33.2	32.8	29.9	28.9	25.8	24.5	22.3	19.2	18.1	15.9	152	-	-		
160	33.5	31.1	30.9	28.1	27.3	24.4	23.5	20.9	18.0	16.9	15.0	160	-	-		
168	31.4	29.1	29.1	26.3	25.7	22.9	22.3	19.4	16.9	15.6	14.1	168	-	-		
176	29.4	27.2	27.4	24.7	24.2	21.4	21.1	18.1	15.8	14.3	13.1	176	-	-		
184	27.6	25.5	25.7	23.2	22.9	20.0	19.9	16.8	14.8	13.2	12.3	184	-	-		
192	-	23.9	24.2	21.7	21.5	18.7	18.7	15.6	13.9	12.1	11.5	192	-	-		
200	-	22.5	22.7	20.3	20.2	17.5	17.7	14.4	13.0	11.0	10.7	200	-	-		
208	-	21.1	-	18.9	18.9	16.2	16.5	13.3	12.0	10.0	9.9	208	-	-		
216	-	-	-	17.7	17.7	15.1	15.3	12.2	11.1	8.9	9.1	216	-	-		
224	-	-	-	16.5	16.8	14.0	14.2	11.1	10.3	8.0	8.3	224	-	-		
232	-	-	-	-	-	12.9	13.2	10.1	9.5	7.2	7.5	232	-	-		
240	-	-	-	-	-	11.8	12.2	9.1	8.8	6.3	6.7	240	-	-		
248	-	-	-	-	-	-	-	8.2	8.2	5.6	6.0	248	-	-		
256	-	-	-	-	-	-	-	7.3	7.5	-	-	256	-	-		
264	-	-	-	-	-	-	-	-	7.0	-	-	264	-	-		

132,300 lb													360°		85%	
196.9 ft																
ft	19.7 ft	39.4 ft		59.1 ft			78.7 ft			98.4 ft			118.1 ft			ft
		0°	0°	20°	40°	0°	20°	40°	0°	20°	40°	0°	20°	40°		
1,000 lb																
48	99.9	-	-	-	-	-	-	-	-	-	-	-	-	-	48	
56	91.1	78.5	-	-	66.8	-	-	-	-	-	-	-	-	-	56	
64	83.3	71.6	62.7	-	61.6	-	-	50.6	-	41.9	-	-	-	-	64	
72	76.2	65.6	58.9	-	57.0	-	-	47.3	-	39.9	-	33.3	-	-	72	
80	70.1	60.6	55.5	51.5	53.0	45.4	-	44.3	-	38.1	-	31.7	-	-	80	
88	64.5	56.2	52.4	49.2	49.3	43.1	38.5	41.6	33.1	-	36.2	-	29.9	-	88	
96	59.6	52.4	49.5	46.9	46.1	40.8	36.9	39.1	31.9	-	34.3	27.8	-	28.3	96	
104	53.9	49.1	46.6	44.8	43.3	38.8	35.5	36.9	30.8	25.9	32.4	26.6	-	26.7	104	
112	46.8	45.8	44.0	42.9	40.6	36.9	34.1	34.7	29.7	25.6	30.8	25.3	-	25.1	112	
120	40.6	40.6	41.5	40.8	38.2	35.1	32.8	32.8	28.6	25.2	28.9	24.2	20.5	23.6	120	
128	35.1	35.1	38.0	38.8	35.6	33.5	31.4	30.9	27.7	24.8	27.2	22.9	19.7	22.1	128	
136	30.2	30.3	33.1	34.9	31.7	31.9	30.0	29.1	26.7	24.4	25.5	21.7	18.9	20.8	136	
144	26.0	26.2	28.6	30.2	27.5	30.5	28.9	27.4	25.6	23.8	23.9	20.3	18.1	19.5	144	
152	22.2	22.5	24.6	25.9	23.8	27.3	27.6	25.1	24.5	23.3	22.3	19.2	17.3	18.1	152	
160	18.8	19.0	20.9	22.0	20.6	23.8	25.8	21.9	23.5	22.8	20.9	18.0	16.5	16.9	160	
168	15.8	16.0	17.7	-	17.6	20.5	22.4	19.0	21.9	22.1	19.1	16.9	15.8	15.6	168	
176	13.0	13.2	14.8	-	14.7	17.4	19.0	16.3	19.7	21.3	17.0	15.8	15.1	14.3	176	
184	10.5	10.8	12.0	-	12.4	14.7	16.0	13.8	17.1	19.1	14.8	14.8	14.4	13.2	184	
192	-	8.6	9.4	-	10.1	12.1	-	11.5	14.5	16.6	12.6	13.9	13.7	12.1	192	
200	-	6.4	7.1	-	8.0	9.8	-	9.5	12.2	13.9	10.6	13.0	12.9	10.7	200	
208	-	-	-	-	-	7.6	-	7.5	10.0	11.4	8.6	11.6	12.3	9.1	208	
216	-	-	-	-	-	5.4	-	5.6	7.9	-	6.7	9.8	11.5	7.4	216	
224	-	-	-	-	-	-	-	-	6.0	-	-	8.1	9.8	5.8	224	
232	-	-	-	-	-	-	-	-	-	-	-	-	-	-	232	
240	-	-	-	-	-	-	-	-	-	-	-	-	-	7.3	240	

352,700 lb		360°		85%	
196.9 ft + 0°					
ft	19.7 ft	39.4 ft		59.1 ft	
		0°	20°	0°	20°
1,000 lb					
36	117.4	-	-	-	-
40	116.5	94.7	-	76.9	-
48	111.8	90.7	-	73.9	-
56	107.5	86.6	83.3	70.8	-
64	103.2	82.8	80.0	67.8	59.5
72	99.3	79.0	76.8	64.9	56.7
80	95.5	75.5	73.6	61.9	54.1
88	91.9	72.1	70.7	59.1	52.0
96	88.4	69.0	68.1	56.4	50.1
104	84.9	66.3	65.4	54.1	48.5
112	81.4	63.6	62.9	51.7	46.9
120	78.2	61.2	60.6	49.8	45.8
128	75.1	59.0	58.5	47.8	44.5
136	72.1	56.9	56.5	46.2	43.5
144	69.1	55.2	54.7	44.8	42.4
152	66.4	53.4	52.9	43.5	41.3
160	63.8	52.0	51.5	42.4	40.5
168	61.5	50.5	50.0	41.4	39.7
176	59.2	49.3	48.7	40.5	38.7
184	53.8	48.1	47.5	39.6	38.0
192	-	46.9	46.3	38.8	37.3
200	-	45.4	45.2	38.0	36.5
208	-	-	-	37.2	35.8
216	-	-	-	36.4	35.1
224	-	-	-	-	34.4

220,500 lb		360°		85%		
196.9 ft + 0°						
ft	19.7 ft	39.4 ft		59.1 ft		
		0°	20°	40°	0°	20°
1,000 lb						
36	117.4	-	-	-	-	-
40	116.5	94.7	-	-	76.9	-
48	111.8	90.7	-	-	73.9	-
56	107.5	86.6	83.3	-	70.8	-
64	103.2	82.8	80.0	68.1	67.8	59.5
72	99.3	79.0	76.8	67.0	64.9	56.7
80	95.5	75.5	73.6	65.9	61.9	54.1
88	91.9	72.1	70.7	64.6	59.1	52.0
96	88.4	69.0	68.1	63.2	56.4	50.1
104	84.9	66.3	65.4	61.7	54.1	48.5
112	81.3	63.6	62.9	60.3	51.7	46.9
120	74.9	61.2	60.6	58.7	49.8	45.8
128	66.8	59.0	58.5	57.1	47.8	44.5
136	59.7	56.9	56.5	55.5	46.2	43.5
144	53.4	53.9	54.7	53.9	44.8	42.4
152	47.6	48.3	50.6	51.7	43.5	41.3
160	42.7	43.2	45.2	46.4	42.4	40.5
168	38.3	38.7	40.6	-	40.0	39.6
176	34.1	34.6	36.1	-	36.3	38.5
184	30.6	31.0	32.3	-	32.7	35.1
192	-	27.6	28.7	-	29.3	31.5
200	-	24.6	25.6	-	26.2	28.1
208	-	-	-	-	23.4	25.1
216	-	-	-	-	20.9	22.2
224	-	-	-	-	-	19.7

352,700 lb		360°		85%	
196.9 ft + 30°					
ft	39.4 ft 0°	59.1 ft 0°	78.7 ft 0°	98.4 ft 0°	118.1 ft 0°
1,000 lb					
48	111.2	87.0	63.6	-	-
56	102.0	80.5	58.7	50.8	42.7
64	93.2	74.4	54.4	47.0	39.6
72	84.8	68.7	50.6	43.7	36.7
80	76.9	63.6	47.4	40.8	34.2
88	69.5	58.6	44.7	38.4	31.9
96	62.8	54.2	42.3	36.1	29.9
104	57.1	50.3	40.4	34.2	28.2
112	51.6	46.6	38.3	32.5	26.6
120	47.0	43.3	36.6	31.0	25.0
128	43.1	40.1	34.8	29.6	23.8
136	39.7	37.4	33.2	28.3	22.7
144	36.9	34.9	31.4	27.0	21.7
152	34.3	32.6	29.8	25.8	20.8
160	32.2	30.4	28.2	24.6	19.8
168	30.2	28.5	26.5	23.5	19.1
176	28.5	26.7	24.9	22.4	18.4
184	26.7	25.1	23.4	21.3	17.7
192	25.0	23.5	22.0	20.3	17.1
200	23.2	22.2	20.6	19.2	16.4
208	-	20.8	19.4	18.1	15.7
216	-	19.3	18.2	17.0	15.0
224	-	-	16.9	16.1	14.4
232	-	-	15.8	15.1	13.7
240	-	-	-	14.0	13.0
248	-	-	-	13.0	12.3
256	-	-	-	-	11.5
264	-	-	-	-	10.4
272	-	-	-	-	9.3

220,500 lb		360°		85%	
196.9 ft + 30°					
ft	39.4 ft 0°	59.1 ft 0°	78.7 ft 0°	98.4 ft 0°	118.1 ft 0°
1,000 lb					
48	111.2	87.0	63.6	-	-
56	102.0	80.5	58.7	50.8	42.7
64	93.2	74.4	54.4	47.0	39.6
72	84.8	68.7	50.6	43.7	36.7
80	76.9	63.6	47.4	40.8	34.2
88	69.5	58.6	44.7	38.4	31.9
96	62.8	54.2	42.3	36.1	29.9
104	57.1	50.3	40.4	34.2	28.2
112	51.6	46.6	38.3	32.5	26.6
120	47.0	43.3	36.6	31.0	25.0
128	43.1	40.1	34.8	29.6	23.8
136	39.7	37.4	33.2	28.3	22.7
144	36.9	34.9	31.4	27.0	21.7
152	34.3	32.6	29.8	25.8	20.8
160	32.2	30.4	28.2	24.6	19.8
168	30.2	28.5	26.5	23.5	19.1
176	28.5	26.7	24.9	22.4	18.4
184	26.7	25.1	23.4	21.3	17.7
192	25.0	23.5	22.0	20.3	17.1
200	23.2	22.2	20.6	19.2	16.4
208	-	20.8	19.4	18.1	15.7
216	-	19.3	18.2	17.0	15.0
224	-	-	16.9	16.1	14.4
232	-	-	15.8	15.1	13.7
240	-	-	-	14.0	13.0
248	-	-	-	13.0	12.3
256	-	-	-	-	11.5
264	-	-	-	-	10.4
272	-	-	-	-	9.3

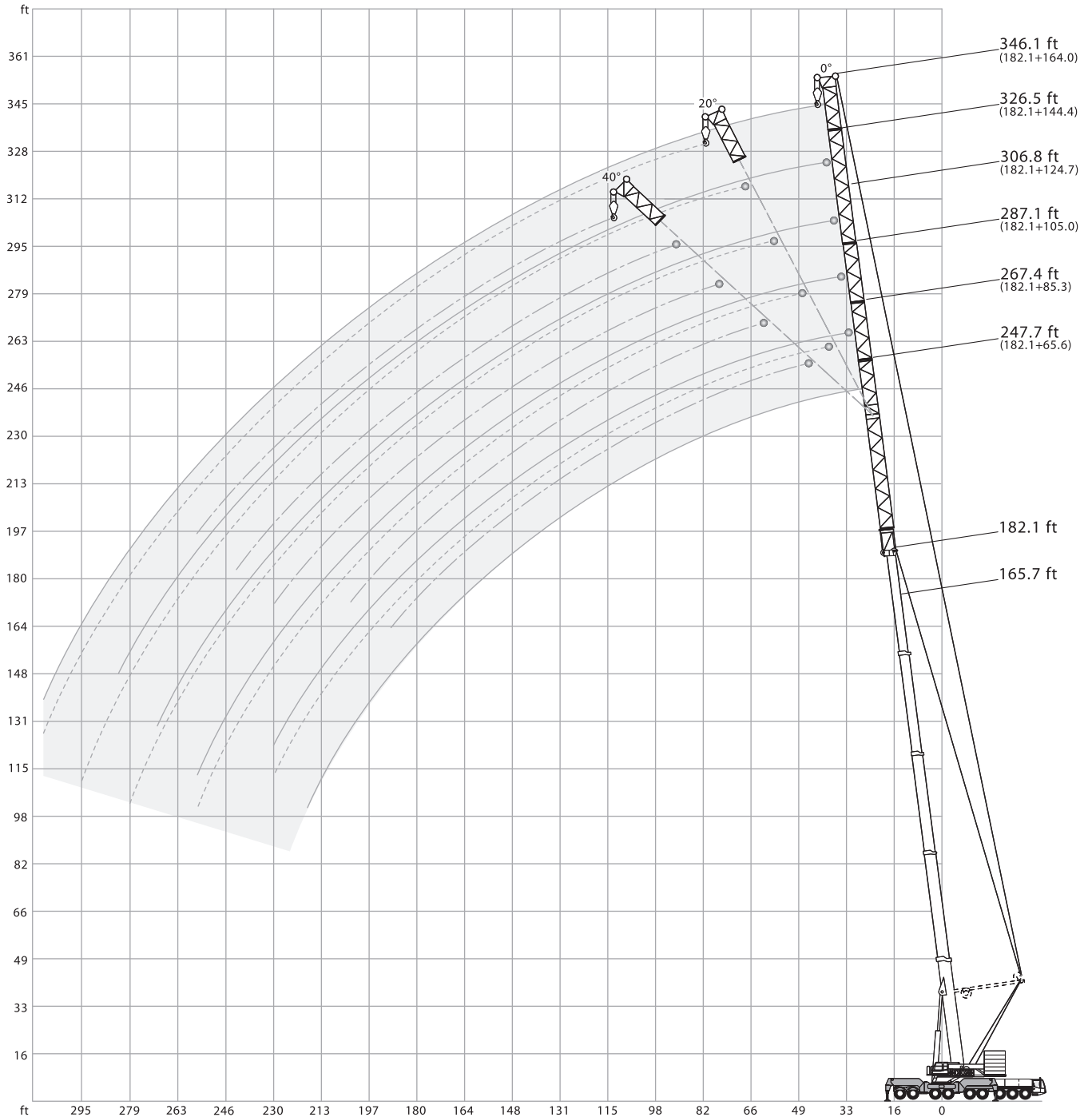
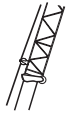

360°															85%			
165.7 ft																		
ft	65.6 ft		85.3 ft			105.0 ft			124.7 ft			144.4 ft			164.0 ft			ft
	0°	0°	20°	40°	0°	20°	40°	0°	20°	40°	0°	20°	40°	0°	20°	40°		
1,000 lb																		
48	101.7	-	-	-	-	-	-	-	-	-	-	-	-	-	-	-	48	
56	92.4	80.5	-	-	-	-	-	-	-	-	-	-	-	-	-	-	56	
64	84.2	73.8	-	-	65.8	-	-	53.7	-	-	-	-	-	-	-	-	64	
72	76.9	68.0	62.9	-	60.5	-	-	51.0	-	-	41.3	-	-	-	-	-	72	
80	70.8	62.7	58.9	55.8	55.8	50.5	-	48.3	-	-	38.9	-	-	34.1	-	-	80	
88	65.5	58.0	55.0	52.8	51.6	48.0	-	45.6	34.8	-	36.8	-	-	32.0	-	-	88	
96	60.8	53.8	51.7	50.0	47.8	45.3	41.3	42.9	33.8	-	34.7	26.1	-	30.0	-	-	96	
104	56.7	50.1	48.5	47.3	44.5	42.8	39.8	40.2	32.9	-	32.7	24.8	-	28.2	-	-	104	
112	53.2	46.8	45.5	44.6	41.5	40.4	38.3	37.8	31.9	26.6	30.8	23.7	-	26.3	21.1	-	112	
120	49.8	43.9	42.9	42.4	39.1	38.1	36.6	35.4	31.1	26.2	29.1	22.7	19.5	24.5	20.3	-	120	
128	46.9	41.3	40.6	40.1	36.7	35.9	34.8	32.9	30.0	25.8	27.3	21.8	19.0	22.9	19.5	-	128	
136	44.3	39.1	38.4	38.1	34.6	33.8	33.1	30.7	28.7	25.3	25.7	20.9	18.6	21.5	18.7	-	136	
144	41.8	37.1	36.5	36.2	32.5	31.8	31.4	28.7	27.6	24.7	24.3	20.3	18.1	19.9	17.7	15.2	144	
152	39.4	35.3	34.8	34.4	30.6	30.0	29.5	26.7	26.3	24.1	22.7	19.5	17.6	18.6	16.8	14.7	152	
160	37.3	33.7	33.2	32.8	28.9	28.4	27.9	25.0	25.2	23.4	21.3	18.7	17.2	17.2	15.8	14.4	160	
168	35.4	32.1	31.7	31.3	27.3	26.8	26.4	23.2	23.7	22.7	19.8	18.0	16.8	15.9	14.9	13.8	168	
176	33.4	30.6	30.2	30.0	25.8	25.1	24.9	21.6	22.3	21.9	18.5	17.3	16.4	14.7	13.8	13.1	176	
184	31.6	29.3	28.8	-	24.3	23.9	23.5	20.2	20.9	21.0	17.3	16.5	15.9	13.6	12.9	12.4	184	
192	29.8	27.9	27.5	-	22.9	22.7	22.3	18.9	19.5	20.0	16.1	15.7	15.3	12.6	11.9	11.7	192	
200	27.9	26.4	26.1	-	21.7	21.5	21.2	17.7	18.0	18.8	14.8	14.9	14.8	11.5	11.0	10.8	200	
208	-	24.9	24.7	-	20.5	20.3	-	16.5	16.7	17.4	13.7	14.0	14.1	10.5	10.1	10.1	208	
216	-	23.3	23.2	-	19.3	19.0	-	15.3	15.5	15.8	12.6	13.1	13.3	9.5	9.3	9.3	216	
224	-	-	-	-	18.0	18.1	-	14.4	14.3	-	11.8	12.3	12.5	8.7	8.5	8.6	224	
232	-	-	-	-	16.9	17.1	-	13.4	13.2	-	10.8	11.4	11.6	7.9	7.7	7.9	232	
240	-	-	-	-	-	16.0	-	12.5	12.2	-	10.1	10.6	-	7.2	7.1	7.2	240	
248	-	-	-	-	-	-	-	11.6	11.5	-	9.3	9.8	-	6.6	6.5	6.7	248	
256	-	-	-	-	-	-	-	10.8	-	-	8.6	9.0	-	5.9	5.9	6.2	256	
264	-	-	-	-	-	-	-	-	-	-	8.1	8.5	-	5.4	5.4	-	264	
272	-	-	-	-	-	-	-	-	-	-	7.6	8.0	-	5.0	5.0	-	272	
280	-	-	-	-	-	-	-	-	-	-	-	7.4	-	4.6	4.7	-	280	

Max. capacities with minimum counterweight
 Further counterweight configurations on request

- 132,300 lb
- 176,400 lb
- 220,500 lb
- 264,600 lb
- 308,600 lb

360°															85%			
182.1 ft																		
ft	65.6 ft		85.3 ft			105.0 ft			124.7 ft			144.4 ft			164.0 ft			ft
	0°	0°	20°	40°	0°	20°	40°	0°	20°	40°	0°	20°	40°	0°	20°	40°		
1,000 lb																		
56	78.5	65.5	-	-	-	-	-	-	-	-	-	-	-	-	-	-	56	
64	72.5	60.5	-	-	52.8	-	-	-	-	-	-	-	-	-	-	-	64	
72	67.1	55.9	51.0	-	49.2	-	-	44.2	-	-	-	-	-	-	-	-	72	
80	62.3	51.9	48.3	45.9	45.8	-	-	41.4	-	-	36.0	-	-	30.5	-	-	80	
88	57.9	48.2	45.6	43.3	42.7	38.2	-	38.6	-	-	33.3	-	-	28.3	-	-	88	
96	54.2	44.8	42.9	40.8	40.1	35.9	32.8	36.0	32.3	-	30.7	-	-	26.0	-	-	96	
104	50.9	41.8	40.2	38.4	37.6	33.6	30.9	33.6	30.8	-	28.5	-	-	24.0	-	-	104	
112	47.9	39.1	37.8	36.0	35.2	31.4	29.0	31.2	29.2	26.8	26.3	23.1	-	22.0	-	-	112	
120	45.1	36.7	35.4	33.9	33.0	29.5	27.2	28.8	27.6	25.5	24.2	21.5	-	20.3	18.6	-	120	
128	42.6	34.4	33.1	31.7	31.0	27.7	25.6	26.7	25.9	24.1	22.4	20.2	18.2	18.5	17.4	-	128	
136	40.2	32.4	30.9	29.7	29.1	25.9	24.1	24.7	24.2	22.6	20.6	18.8	17.2	17.1	16.3	-	136	
144	38.2	30.5	29.2	27.9	27.4	24.3	22.6	22.8	22.6	21.2	19.0	17.7	16.4	15.7	15.3	-	144	
152	36.1	28.7	27.3	26.0	25.6	23.0	21.2	20.9	20.9	19.9	17.5	16.4	15.3	14.2	14.1	13.3	152	
160	34.2	27.0	25.7	24.4	24.0	21.6	20.1	19.3	19.3	18.5	16.1	15.3	14.3	13.0	12.9	12.2	160	
168	32.5	25.5	24.2	22.9	22.4	20.3	18.9	17.8	17.9	17.2	14.8	14.2	13.4	11.8	11.8	11.2	168	
176	30.9	24.0	22.7	21.6	20.7	18.9	17.8	16.3	16.5	15.8	13.4	13.2	12.5	10.7	10.7	10.3	176	
184	29.3	22.7	21.5	20.4	19.2	17.8	16.7	15.1	15.2	14.6	12.3	12.1	11.5	9.8	9.8	9.5	184	
192	27.7	21.3	20.3	-	17.8	16.7	15.6	13.9	13.9	13.4	11.3	11.0	10.6	8.8	8.8	8.6	192	
200	26.0	20.0	19.2	-	16.4	15.7	14.6	13.0	12.8	12.4	10.3	10.1	9.7	7.9	7.9	7.8	200	
208	24.5	18.8	18.2	-	15.3	14.7	13.6	12.0	11.9	11.4	9.4	9.2	8.8	7.0	7.0	7.1	208	
216	23.0	17.7	17.3	-	14.2	13.7	-	11.1	11.1	10.4	8.4	8.2	8.0	6.2	6.2	6.4	216	
224	-	16.4	16.3	-	13.1	12.9	-	10.2	10.3	9.7	7.6	7.4	7.3	5.5	5.5	5.8	224	
232	-	15.3	-	-	12.1	12.1	-	9.5	9.5	-	6.8	6.6	6.6	-	-	5.1	232	
240	-	-	-	-	11.3	11.5	-	8.7	8.7	-	6.1	6.0	6.0	-	-	4.6	240	
248	-	-	-	-	10.6	10.8	-	8.0	8.0	-	5.5	5.4	5.4	-	-	-	248	
256	-	-	-	-	-	-	-	7.5	7.5	-	-	-	-	-	-	-	256	
264	-	-	-	-	-	-	-	6.7	7.0	-	-	-	-	-	-	-	264	
272	-	-	-	-	-	-	-	6.2	6.4	-	-	-	-	-	-	-	272	

Max. capacities with minimum counterweight
 Further counterweight configurations on request

- 132,300 lb
- 176,400 lb
- 220,500 lb
- 264,600 lb
- 308,600 lb

A large rectangular area with horizontal lines, intended for taking notes.

LF-SSL 0°/30°

AC 700-9

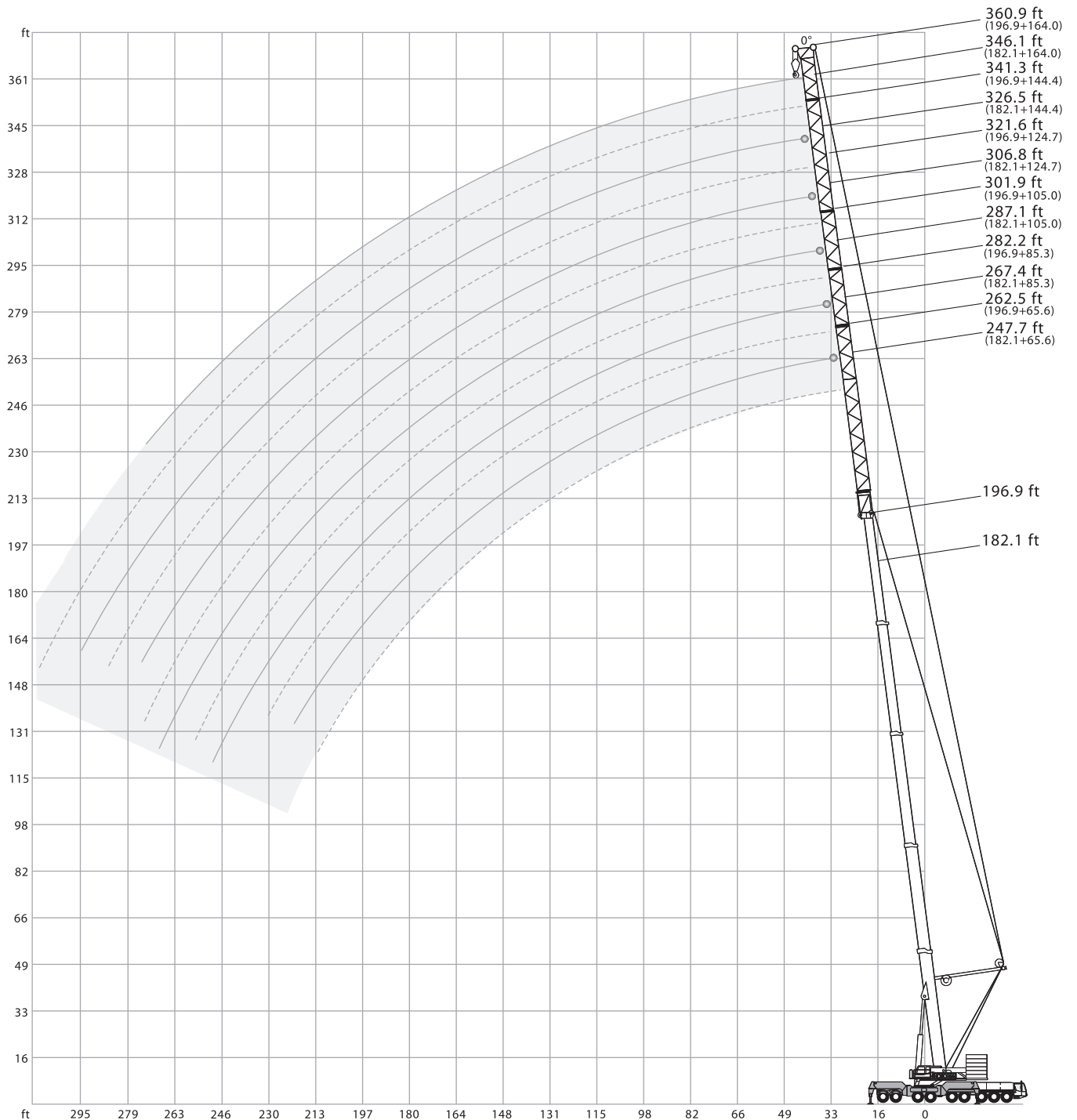

360°															85%			
182.1 ft + 0°																		
ft	65.6 ft		85.3 ft			105.0 ft			124.7 ft			144.4 ft			164.0 ft			ft
	0°	0°	20°	40°	0°	20°	40°	0°	20°	40°	0°	20°	40°	0°	20°	40°		
1,000 lb																		
40	92.8	-	-	-	-	-	-	-	-	-	-	-	-	-	-	-	40	
48	89.6	69.0	-	-	57.8	-	-	-	-	-	-	-	-	-	-	-	48	
56	86.6	67.4	-	-	57.1	-	-	48.7	-	-	41.2	-	-	-	-	-	56	
64	83.3	65.9	61.2	-	56.2	-	-	48.0	-	-	40.1	-	-	31.2	-	-	64	
72	80.3	64.2	59.4	57.8	54.9	49.2	-	47.0	-	-	39.0	-	-	30.2	-	-	72	
80	77.1	62.3	57.5	55.9	53.6	48.1	-	45.9	37.0	-	38.0	-	-	29.4	-	-	80	
88	74.2	60.2	55.5	54.0	52.1	46.9	43.5	44.5	35.7	-	36.8	-	-	28.4	-	-	88	
96	71.2	58.2	53.5	52.2	50.5	45.6	42.3	43.2	34.5	-	35.6	28.1	-	27.4	-	-	96	
104	68.3	56.2	51.6	50.3	48.7	44.1	40.8	41.6	33.2	27.8	34.3	27.0	-	26.4	21.7	-	104	
112	65.3	54.1	49.5	48.2	47.1	42.7	39.4	40.3	32.1	27.3	33.0	26.2	-	25.5	20.9	-	112	
120	62.6	52.0	47.6	46.3	45.2	41.1	38.0	38.6	31.1	26.5	31.9	25.4	21.7	24.5	20.3	-	120	
128	59.7	49.8	45.7	44.4	43.3	39.5	36.5	37.0	30.2	25.9	30.5	24.6	21.3	23.6	19.6	-	128	
136	57.0	47.8	43.9	42.5	41.4	37.8	35.0	35.6	29.3	25.3	29.3	23.9	20.8	22.7	19.1	15.1	136	
144	54.6	45.7	42.2	40.9	39.8	36.2	33.6	34.0	28.5	24.7	28.3	23.2	20.3	21.9	18.3	14.8	144	
152	51.9	43.8	40.6	39.2	37.9	34.8	32.0	32.7	27.7	24.0	27.2	22.6	19.8	20.8	17.8	14.5	152	
160	49.6	41.7	39.2	37.7	36.3	33.3	30.7	31.3	26.9	23.4	26.1	22.1	19.2	20.0	17.2	14.0	160	
168	47.4	39.9	37.7	36.2	34.8	32.0	29.4	30.0	26.1	22.8	25.2	21.6	18.7	19.3	16.7	13.7	168	
176	45.3	38.2	36.4	34.4	33.3	30.8	28.2	28.8	25.3	22.1	24.4	21.0	18.2	18.6	16.2	13.3	176	
184	43.4	36.5	35.1	32.6	31.8	29.6	27.1	27.7	24.4	21.4	23.6	20.4	17.6	18.1	15.7	12.9	184	
192	41.5	35.0	33.9	-	30.4	28.4	26.0	26.7	23.7	20.8	22.8	19.7	17.3	17.5	15.3	12.7	192	
200	39.9	33.5	32.7	-	29.2	27.4	25.1	25.8	23.0	20.1	22.1	19.2	16.8	17.0	14.8	12.3	200	
208	37.5	32.1	31.6	-	28.0	26.4	-	24.9	22.3	19.5	21.5	18.7	16.2	16.4	14.3	12.1	208	
216	34.6	30.7	30.7	-	26.8	25.4	-	24.1	21.7	18.8	21.0	18.1	15.7	15.9	13.9	11.7	216	
224	-	29.8	29.8	-	25.7	24.5	-	23.3	20.9	18.2	20.3	17.6	15.2	15.5	13.5	11.4	224	
232	-	28.8	-	-	24.8	23.6	-	22.4	20.1	-	19.7	17.0	14.7	15.1	13.1	10.9	232	
240	-	-	-	-	23.9	22.8	-	21.6	19.4	-	19.1	16.5	14.2	14.7	12.7	10.7	240	
248	-	-	-	-	23.1	22.0	-	21.0	18.7	-	18.6	15.9	-	14.3	12.4	10.3	248	
256	-	-	-	-	-	-	-	20.5	17.8	-	18.1	15.2	-	14.1	12.1	9.9	256	
264	-	-	-	-	-	-	-	20.0	17.0	-	17.5	14.7	-	13.7	11.7	9.6	264	
272	-	-	-	-	-	-	-	-	16.2	-	17.0	14.1	-	13.3	11.4	-	272	
280	-	-	-	-	-	-	-	-	-	-	16.5	13.6	-	13.1	11.1	-	280	
288	-	-	-	-	-	-	-	-	-	-	15.1	13.2	-	12.8	10.7	-	288	
296	-	-	-	-	-	-	-	-	-	-	-	-	-	12.4	10.3	-	296	
304	-	-	-	-	-	-	-	-	-	-	-	-	-	11.1	9.9	-	304	
312	-	-	-	-	-	-	-	-	-	-	-	-	-	-	9.6	-	312	

Max. capacities with minimum counterweight
 Further counterweight configurations on request

- 132,300 lb
- 176,400 lb
- 220,500 lb
- 264,600 lb
- 308,600 lb

360°							85%						
182.1 ft + 30°							196.9 ft + 30°						
ft	65.6 ft 0°	85.3 ft 0°	105.0 ft 0°	124.7 ft 0°	144.4 ft 0°	164.0 ft 0°	ft	65.6 ft 0°	85.3 ft 0°	105.0 ft 0°	124.7 ft 0°	144.4 ft 0°	164.0 ft 0°
1,000 lb							1,000 lb						
48	104.4	-	-	-	-	-	48	95.2	-	-	-	-	-
56	95.0	85.1	73.2	58.6	-	-	56	86.6	78.3	59.5	-	-	-
64	86.4	77.6	67.7	55.3	46.3	37.5	64	79.1	72.3	59.5	52.2	44.3	-
72	78.4	70.7	62.3	52.1	43.5	35.1	72	72.0	66.5	57.8	49.0	41.5	32.4
80	71.0	64.5	57.5	48.9	40.8	33.0	80	65.9	61.1	53.8	46.1	38.9	30.8
88	64.5	58.8	53.2	46.0	38.5	31.1	88	60.2	56.1	49.9	43.2	36.5	29.0
96	58.6	53.6	49.1	43.1	36.4	29.2	96	55.1	51.4	46.3	40.5	34.4	27.5
104	53.3	49.0	45.3	40.5	34.3	27.5	104	50.6	47.2	42.8	37.9	32.3	26.1
112	48.3	44.8	41.7	37.8	32.3	25.9	112	46.3	43.2	39.3	35.4	30.3	24.6
120	44.1	41.0	38.6	35.5	30.6	24.5	120	42.5	39.6	36.3	33.1	28.4	23.1
128	40.3	37.6	35.7	33.2	28.9	23.1	128	39.0	36.2	33.5	30.9	26.7	21.8
136	36.9	34.6	33.0	30.9	27.3	21.9	136	35.8	33.3	30.8	28.9	25.1	20.6
144	34.0	32.1	30.6	28.9	25.6	20.7	144	33.0	30.6	28.4	26.9	23.5	19.3
152	31.2	29.7	28.4	26.9	24.1	19.5	152	30.3	28.2	26.2	24.9	22.1	18.1
160	29.1	27.7	26.4	25.0	22.6	18.2	160	27.9	26.2	24.2	23.1	20.6	16.9
168	27.1	25.9	24.5	23.2	21.1	17.1	168	25.7	24.3	22.4	21.5	19.2	15.8
176	25.4	24.3	22.7	21.6	19.6	16.0	176	23.7	22.5	20.7	19.9	17.8	14.7
184	23.9	22.8	21.3	20.0	18.3	15.1	184	22.0	21.0	19.4	18.2	16.5	13.6
192	22.4	21.3	20.0	18.5	16.9	14.1	192	20.4	19.6	18.0	16.7	15.2	12.6
200	21.1	20.1	18.7	17.1	15.7	13.0	200	19.1	18.4	16.8	15.3	14.0	11.5
208	19.8	18.9	17.4	15.9	14.5	12.1	208	17.8	17.2	15.7	14.1	12.8	10.5
216	-	17.7	16.2	14.7	13.3	11.3	216	16.6	16.2	14.6	12.9	11.5	9.5
224	-	16.5	15.1	13.5	12.2	10.4	224	15.5	14.9	13.7	11.8	10.5	8.6
232	-	15.2	14.0	12.6	11.1	9.5	232	-	13.8	12.7	10.7	9.6	7.9
240	-	-	12.9	11.8	10.2	8.8	240	-	12.5	11.8	9.8	8.7	7.1
248	-	-	11.9	10.9	9.4	8.1	248	-	-	10.8	8.9	7.8	6.2
256	-	-	-	10.1	8.6	7.5	256	-	-	9.9	8.1	7.0	5.5
264	-	-	-	9.4	7.9	6.8	264	-	-	-	7.4	6.5	4.9
272	-	-	-	-	7.3	6.2	272	-	-	-	6.9	6.0	-
280	-	-	-	-	6.9	5.7	280	-	-	-	-	5.4	-
288	-	-	-	-	-	5.2	288	-	-	-	-	5.1	-
296	-	-	-	-	-	4.8	296	-	-	-	-	4.9	-

Max. capacities with minimum counterweight
 Further counterweight configurations on request

- 132,300 lb
- 176,400 lb
- 220,500 lb
- 264,600 lb
- 308,600 lb

A large rectangular area with horizontal lines, intended for taking notes.

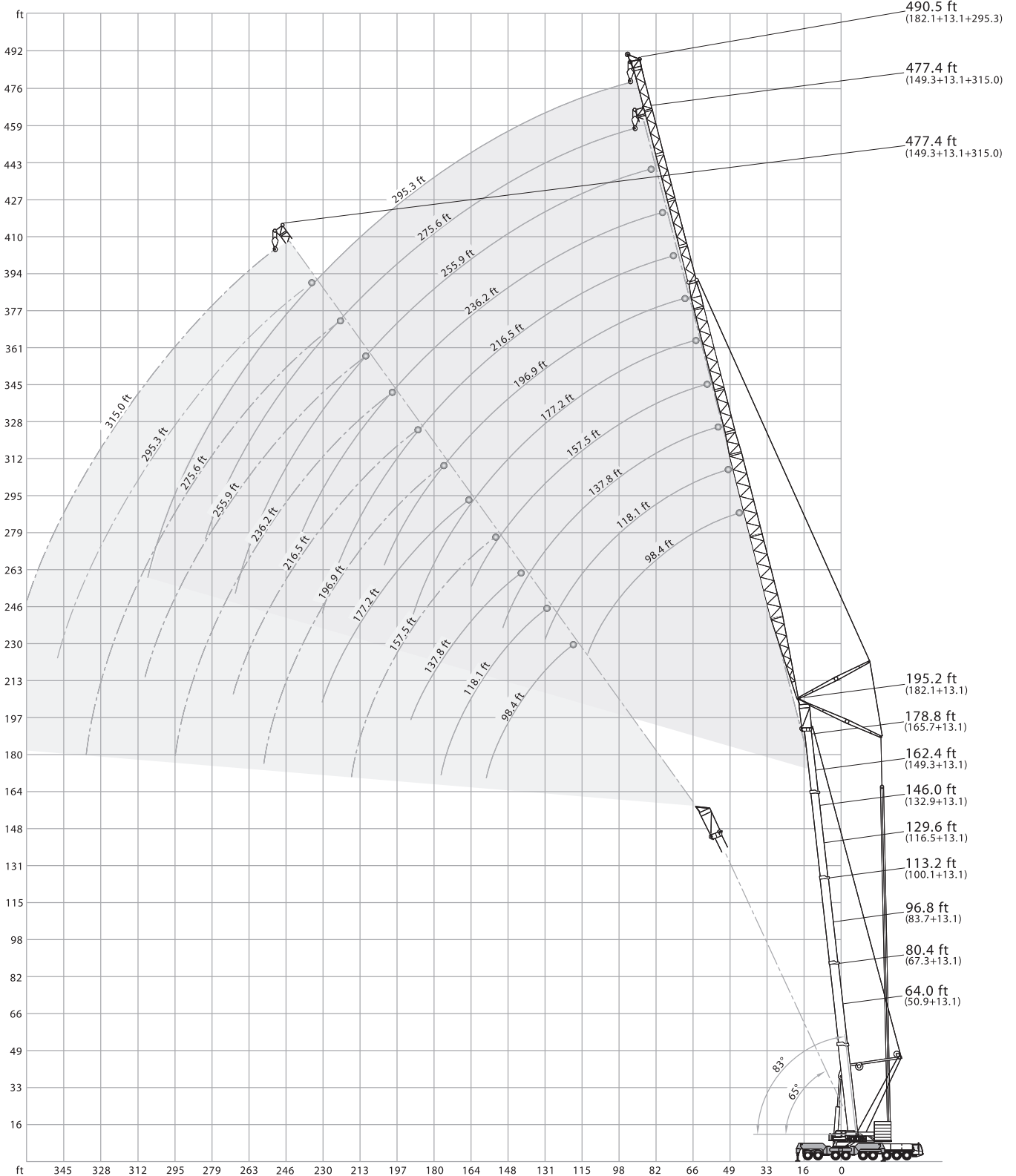

360°															85%		
50.9 ft + 13.1 ft																	
78.7 ft			98.4 ft			118.1 ft			137.8 ft			157.5 ft			177.2 ft		
83° 73° 65°			83° 73° 65°			83° 73° 65°			83° 73° 65°			83° 73° 65°			83° 73° 65°		
ft																	
1,000 lb																	
40	270.1	-	-	-	-	-	-	-	-	-	-	-	-	-	-	-	-
48	256.7	-	-	225.7	-	-	195.5	-	-	-	-	-	-	-	-	-	-
56	244.4	-	-	222.7	-	-	192.8	-	-	160.9	-	-	133.4	-	-	-	-
64	228.1	224.8	-	221.0	-	-	190.1	-	-	160.1	-	-	133.4	-	-	114.6	-
72	198.1	206.6	-	210.8	196.4	-	188.5	-	-	158.8	-	-	133.4	-	-	114.6	-
80	-	189.3	184.9	192.6	187.1	-	186.1	169.3	-	157.2	-	-	133.0	-	-	114.6	-
88	-	111.5	168.7	171.5	171.4	-	175.3	165.7	-	155.6	-	-	130.3	-	-	114.2	-
96	-	-	154.0	139.2	156.6	152.2	154.8	155.1	150.7	153.6	147.0	-	127.6	124.6	-	112.1	-
104	-	-	-	-	143.7	139.3	130.7	142.6	138.2	143.9	140.1	-	125.8	123.6	-	108.7	108.4
112	-	-	-	-	-	128.4	107.8	130.6	127.3	125.8	129.5	126.2	122.9	122.3	-	105.6	106.8
120	-	-	-	-	-	-	-	121.2	118.2	108.6	120.5	116.8	113.8	111.3	111.0	101.6	101.4
128	-	-	-	-	-	-	-	-	110.2	92.5	112.4	108.5	103.5	103.5	107.4	97.0	101.4
136	-	-	-	-	-	-	-	-	102.9	75.6	104.3	101.8	90.9	103.2	100.7	91.6	98.7
144	-	-	-	-	-	-	-	-	-	-	94.2	95.1	78.8	97.2	94.0	86.2	95.0
152	-	-	-	-	-	-	-	-	-	-	-	89.5	66.7	90.4	87.5	75.9	89.5
160	-	-	-	-	-	-	-	-	-	-	-	-	-	81.7	82.1	66.7	83.2
168	-	-	-	-	-	-	-	-	-	-	-	-	-	-	77.2	57.5	76.9
176	-	-	-	-	-	-	-	-	-	-	-	-	-	-	-	-	70.2
184	-	-	-	-	-	-	-	-	-	-	-	-	-	-	-	-	67.4

196.9 ft																		216.5 ft			236.2 ft			255.9 ft			275.6 ft			295.3 ft			315.0 ft		
ft																		1,000 lb																	
72	92.6	-	-	-	-	-	-	-	-	-	-	-	-	-	-	-	-																		
80	92.6	-	-	77.0	-	-	66.1	-	-	-	-	-	-	-	-	-	-																		
88	92.6	-	-	75.6	-	-	66.1	-	-	53.2	-	-	-	-	-	-	-																		
96	92.6	-	-	74.3	-	-	66.1	-	-	52.1	-	-	42.9	-	-	34.7	-																		
104	92.6	-	-	72.9	-	-	66.1	-	-	51.2	-	-	42.0	-	-	33.8	-																		
112	92.6	88.2	-	71.7	-	-	65.9	-	-	50.2	-	-	41.0	-	-	32.8	-																		
120	92.6	87.9	-	71.3	71.7	-	65.3	-	-	49.2	-	-	40.1	-	-	32.0	-																		
128	92.6	87.1	-	70.0	71.1	-	64.5	65.0	-	48.4	-	-	39.0	-	-	31.2	-																		
136	92.6	86.3	-	68.6	69.7	-	63.7	65.0	47.6	48.7	-	-	38.1	-	-	30.4	-																		
144	89.4	85.0	82.7	67.3	69.4	-	62.9	65.0	46.8	47.9	-	-	37.1	-	-	29.6	-																		
152	82.5	83.4	81.4	65.9	68.2	68.2	62.1	65.0	45.9	47.1	-	-	36.0	37.3	-	28.8	-																		
160	73.5	80.7	79.6	64.0	66.8	66.8	61.3	65.0	44.9	46.3	-	-	35.2	36.3	-	28.0	29.1																		
168	65.8	77.4	75.9	61.9	65.3	65.5	59.6	65.0	44.2	45.4	-	-	34.1	35.2	-	27.2	28.3																		
176	58.4	73.3	71.2	59.6	63.7	64.1	57.0	65.0	43.4	44.6	45.1	33.2	34.3	-	26.6	27.5	-																		
184	50.9	68.2	67.3	54.7	62.0	62.9	54.2	63.0	42.4	43.8	44.2	32.3	33.4	-	25.9	26.8	-																		
192	-	62.3	63.7	49.2	60.1	61.3	51.1	60.6	41.5	43.0	43.2	31.4	32.5	33.7	25.2	26.1	-																		
200	-	54.6	60.3	43.1	57.7	58.4	46.5	58.1	40.5	42.2	42.3	30.5	31.6	32.8	24.7	25.6	27.5																		
208	-	-	57.3	36.9	53.2	55.5	41.6	54.7	39.5	41.4	41.4	29.7	30.8	31.9	24.2	25.0	26.7																		
216	-	-	-	47.1	52.6	52.6	36.5	50.5	38.4	40.6	40.6	28.9	30.0	31.1	23.6	24.3	25.8																		
224	-	-	-	-	50.2	31.5	45.6	48.8	35.1	39.7	39.8	28.3	29.4	30.3	23.1	23.7	25.0																		
232	-	-	-	-	-	-	40.6	46.3	31.4	38.8	39.0	27.6	28.7	29.5	22.6	23.2	24.3																		
240	-	-	-	-	-	-	35.3	44.2	27.4	38.0	38.2	26.9	28.0	28.7	22.2	22.7	23.6																		
248	-	-	-	-	-	-	-	40.5	23.0	35.2	37.6	25.5	27.4	28.1	21.7	22.2	23.0																		
256	-	-	-	-	-	-	-	-	16.3	36.8	23.8	26.9	27.5	21.2	21.8	22.5	16.1																		
264	-	-	-	-	-	-	-	-	-	34.9	20.3	26.4	26.9	20.9	21.4	21.9	15.7																		
272	-	-	-	-	-	-	-	-	-	-	-	25.5	26.3	20.9	21.0	21.5	15.3																		
280	-	-	-	-	-	-	-	-	-	-	-	-	25.9	17.0	20.6	21.1	14.9																		
288	-	-	-	-	-	-	-	-	-	-	-	-	-	14.0	20.3	20.7	14.5																		
296	-	-	-	-	-	-	-	-	-	-	-	-	-	-	11.2	20.3	13.9																		
304	-	-	-	-	-	-	-	-	-	-	-	-	-	-	19.9	11.6	13.9																		
312	-	-	-	-	-	-	-	-	-	-	-	-	-	-	-	-	13.5																		
320	-	-	-	-	-	-	-	-	-	-	-	-	-	-	-	-	13.2																		

Max. capacities with minimum counterweight - Further counterweight configurations on request

- 132,300 lb
- 176,400 lb
- 220,500 lb
- 264,600 lb
- 308,600 lb
- 352,700 lb



360°																85%		
67.3 ft + 13.1 ft																		
78.7 ft																		
98.4 ft																		
118.1 ft																		
137.8 ft																		
157.5 ft																		
177.2 ft																		
ft	83° 73° 65°			83° 73° 65°			83° 73° 65°			83° 73° 65°			83° 73° 65°			83° 73° 65°		
1,000 lb																		
48	248.5	-	-	215.4	-	-	172.4	-	-	-	-	-	-	-	-	-	-	-
56	235.4	-	-	209.3	-	-	170.8	-	-	140.0	-	-	-	-	114.6	-	-	-
64	220.1	-	-	203.9	-	-	169.8	-	-	139.2	-	-	-	-	114.6	-	-	97.0
72	204.3	192.1	-	197.5	-	-	168.7	-	-	138.9	-	-	-	-	114.6	-	-	97.0
80	-	178.9	-	188.6	167.2	-	166.9	146.0	-	137.6	-	-	-	-	114.4	-	-	97.0
88	-	167.2	156.7	174.2	158.2	-	162.0	141.9	-	135.8	-	-	-	-	113.1	-	-	97.0
96	-	94.5	147.3	150.5	149.5	140.6	153.9	137.2	-	134.9	124.3	-	-	-	112.4	-	-	97.0
104	-	-	136.0	-	140.1	133.1	138.8	131.8	-	128.9	120.6	-	-	-	111.5	108.4	-	96.1
112	-	-	-	-	75.0	124.0	116.7	126.3	118.8	121.6	117.6	-	-	-	109.9	105.7	-	94.7
120	-	-	-	-	-	114.9	-	118.2	113.8	109.6	112.6	104.9	-	-	104.6	103.0	-	93.1
128	-	-	-	-	-	-	-	110.2	105.8	96.9	108.0	100.8	-	-	98.1	100.3	91.5	89.8
136	-	-	-	-	-	-	-	-	98.5	81.9	101.8	96.8	-	-	90.0	96.8	89.6	86.6
144	-	-	-	-	-	-	-	-	92.8	-	95.1	91.7	-	-	81.9	92.8	87.2	81.8
152	-	-	-	-	-	-	-	-	-	-	46.5	85.3	-	-	71.1	87.5	84.2	76.4
160	-	-	-	-	-	-	-	-	-	-	-	79.9	-	-	-	82.1	78.8	70.2
168	-	-	-	-	-	-	-	-	-	-	-	-	-	-	38.7	73.7	73.7	61.4
176	-	-	-	-	-	-	-	-	-	-	-	-	-	-	-	69.0	51.7	71.1
184	-	-	-	-	-	-	-	-	-	-	-	-	-	-	-	-	-	65.3
192	-	-	-	-	-	-	-	-	-	-	-	-	-	-	-	-	-	-
200	-	-	-	-	-	-	-	-	-	-	-	-	-	-	-	-	-	57.6

196.9 ft																		
216.5 ft																		
236.2 ft																		
255.9 ft																		
275.6 ft																		
295.3 ft																		
315.0 ft																		
ft	1,000 lb																	
72	81.6	-	-	-	-	-	-	-	-	-	-	-	-	-	-	-	-	-
80	81.6	-	-	66.1	-	-	57.1	-	-	-	-	-	-	-	-	-	-	-
88	81.6	-	-	65.7	-	-	56.8	-	-	47.7	-	-	-	-	-	-	-	-
96	81.6	-	-	65.2	-	-	56.7	-	-	47.1	-	-	38.4	-	-	30.7	-	-
104	81.6	-	-	64.5	-	-	56.7	-	-	46.8	-	-	38.0	-	-	30.0	-	24.2
112	81.6	-	-	63.9	-	-	56.4	-	-	46.3	-	-	37.4	-	-	29.3	-	23.3
120	81.6	77.2	-	63.1	-	-	56.4	-	-	45.7	-	-	36.9	-	-	28.7	-	22.7
128	81.6	77.2	-	62.5	64.9	-	56.3	-	-	45.1	-	-	36.3	-	-	28.0	-	21.9
136	81.6	76.4	-	61.9	64.1	-	56.1	55.6	-	44.4	-	-	35.5	-	-	27.3	-	21.3
144	79.5	76.1	-	61.1	63.3	-	55.8	55.6	-	43.9	44.8	-	34.6	-	-	26.7	-	20.5
152	76.4	74.6	69.3	60.2	62.5	-	55.4	55.6	-	43.1	44.2	-	33.8	35.2	-	26.1	-	20.0
160	71.5	72.3	67.9	58.6	61.8	-	54.7	55.6	-	42.4	43.5	-	33.0	34.4	-	25.4	-	19.5
168	66.8	70.7	66.4	56.6	60.8	58.9	54.1	55.6	-	41.7	42.9	-	32.2	33.5	-	24.9	25.9	18.9
176	61.4	68.6	64.8	54.1	59.7	57.3	53.1	55.6	53.0	40.9	42.2	-	31.4	32.5	-	24.3	25.2	18.4
184	54.1	66.3	63.0	51.7	58.3	55.7	51.8	54.9	52.5	40.1	41.4	42.1	30.6	31.7	-	23.7	24.7	17.8
192	-	63.4	60.8	49.0	56.8	54.2	50.2	53.9	51.9	39.3	40.6	41.3	29.8	31.0	-	23.0	24.1	17.3
200	-	59.0	57.4	44.9	55.3	53.1	47.8	52.6	51.1	38.3	40.0	40.5	28.8	30.3	31.5	22.5	23.6	16.9
208	-	26.6	54.5	39.4	53.4	51.7	43.8	51.3	49.9	37.5	39.3	39.7	28.1	29.5	30.6	22.2	23.1	16.5
216	-	-	51.8	-	51.3	49.9	38.7	49.9	48.6	36.7	38.6	38.9	27.4	28.7	29.8	21.6	22.5	16.1
224	-	-	-	-	45.3	47.6	33.6	47.4	46.2	35.5	37.8	38.2	26.7	28.0	29.1	21.1	22.0	15.7
232	-	-	-	-	-	45.3	-	44.2	43.9	33.4	37.1	37.5	26.1	27.4	28.5	20.6	21.4	15.3
240	-	-	-	-	-	-	-	39.2	41.8	29.2	36.4	36.8	25.5	26.9	27.8	20.2	20.9	14.9
248	-	-	-	-	-	-	-	-	39.9	24.9	35.5	36.1	25.0	26.3	27.1	19.8	20.5	14.5
256	-	-	-	-	-	-	-	-	-	-	34.6	35.5	24.4	25.8	26.4	19.4	20.1	14.1
264	-	-	-	-	-	-	-	-	-	-	30.1	35.0	21.3	25.3	25.9	19.0	19.7	13.7
272	-	-	-	-	-	-	-	-	-	-	-	34.2	-	24.8	25.4	18.4	19.3	13.3
280	-	-	-	-	-	-	-	-	-	-	-	-	-	24.4	25.0	17.6	18.8	12.9
288	-	-	-	-	-	-	-	-	-	-	-	-	-	-	24.6	15.3	18.5	12.6
296	-	-	-	-	-	-	-	-	-	-	-	-	-	-	-	18.2	18.7	12.3
304	-	-	-	-	-	-	-	-	-	-	-	-	-	-	-	-	18.2	11.5
312	-	-	-	-	-	-	-	-	-	-	-	-	-	-	-	-	18.0	12.0
320	-	-	-	-	-	-	-	-	-	-	-	-	-	-	-	-	-	11.7
328	-	-	-	-	-	-	-	-	-	-	-	-	-	-	-	-	-	11.8

Max. capacities with minimum counterweight · Further counterweight configurations on request



360°																85%		
83.7 ft + 13.1 ft																		
ft	78.7 ft			98.4 ft			118.1 ft			137.8 ft			157.5 ft			177.2 ft		
	83°	73°	65°	83°	73°	65°	83°	73°	65°	83°	73°	65°	83°	73°	65°	83°	73°	65°
	1,000 lb																	
48	241.2	-	-	203.2	-	-	-	-	-	-	-	-	-	-	-	-	-	-
56	226.0	-	-	198.8	-	-	167.6	-	-	133.4	-	-	-	-	-	-	-	-
64	206.1	-	-	191.2	-	-	167.6	-	-	133.4	-	-	108.0	-	-	-	-	-
72	183.5	-	-	181.0	-	-	166.5	-	-	133.4	-	-	108.0	-	-	90.4	-	-
80	-	154.8	-	170.3	148.2	-	162.1	-	-	132.1	-	-	108.0	-	-	90.4	-	-
88	-	145.0	-	159.1	137.9	-	155.4	132.4	-	130.7	-	-	108.0	-	-	90.4	-	-
96	-	138.6	123.7	147.7	129.2	-	147.3	124.4	-	129.8	118.5	-	108.0	-	-	90.4	-	-
104	-	80.7	116.6	-	123.0	111.2	136.0	118.6	-	126.2	112.2	-	108.0	-	-	90.4	-	-
112	-	-	-	-	117.8	104.4	123.3	113.4	103.3	121.8	106.7	-	107.9	101.1	-	90.4	89.2	-
120	-	-	-	-	65.0	99.4	-	110.4	97.6	112.4	102.3	-	105.2	96.1	-	90.4	87.6	-
128	-	-	-	-	-	96.4	-	106.3	92.0	101.9	97.5	88.7	100.8	92.0	-	89.3	85.4	-
136	-	-	-	-	-	-	-	100.7	88.0	87.4	94.3	83.9	94.4	87.7	80.6	87.4	83.3	-
144	-	-	-	-	-	-	-	-	86.0	-	91.6	80.6	87.4	85.0	76.2	82.9	81.6	-
152	-	-	-	-	-	-	-	-	-	-	86.4	76.8	75.3	83.4	72.4	77.5	79.2	72.4
160	-	-	-	-	-	-	-	-	-	-	40.8	74.5	-	79.9	69.7	72.2	77.4	69.3
168	-	-	-	-	-	-	-	-	-	-	-	-	-	74.8	67.5	64.6	73.7	66.2
176	-	-	-	-	-	-	-	-	-	-	-	-	-	70.1	65.9	54.8	69.0	64.0
184	-	-	-	-	-	-	-	-	-	-	-	-	-	-	62.7	-	65.2	61.0
192	-	-	-	-	-	-	-	-	-	-	-	-	-	-	-	-	28.1	57.8
200	-	-	-	-	-	-	-	-	-	-	-	-	-	-	-	-	-	54.7

ft	196.9 ft		216.5 ft		236.2 ft		255.9 ft		275.6 ft		295.3 ft		315.0 ft	
	83°	73°	83°	73°	83°	73°	83°	73°	83°	73°	83°	73°	83°	73°
	1,000 lb													
72	79.4	-	-	-	-	-	-	-	-	-	-	-	-	-
80	79.4	-	-	61.7	-	-	-	-	-	-	-	-	-	-
88	79.4	-	-	61.7	-	-	52.9	-	-	46.3	-	-	-	-
96	79.4	-	-	61.7	-	-	52.9	-	-	46.3	-	-	37.3	-
104	79.4	-	-	61.7	-	-	52.9	-	-	46.3	-	-	37.3	-
112	79.4	-	-	61.7	-	-	52.9	-	-	46.3	-	-	37.0	-
120	79.4	-	-	61.5	-	-	52.9	-	-	46.3	-	-	36.8	-
128	79.4	75.5	-	61.4	-	-	52.9	-	-	46.2	-	-	36.6	-
136	79.4	75.0	-	61.1	64.7	-	52.9	-	-	45.8	-	-	36.4	-
144	78.3	75.0	-	61.1	64.4	-	52.9	51.8	-	45.2	-	-	35.8	-
152	76.6	73.7	-	60.7	63.9	-	52.9	51.8	-	44.5	45.8	-	34.9	-
160	72.6	72.8	63.3	59.9	63.2	-	52.9	51.8	-	43.8	45.2	-	34.1	35.9
168	68.3	71.4	61.9	58.7	62.6	-	52.6	51.8	-	43.1	44.6	-	33.3	35.0
176	63.7	68.7	60.6	56.9	61.8	57.0	52.1	51.8	-	42.4	44.0	-	32.5	34.1
184	56.6	65.2	59.1	55.2	60.9	54.9	50.7	51.8	50.1	41.8	43.3	-	31.7	33.3
192	-	61.7	57.4	52.6	59.6	53.0	49.0	51.7	49.2	41.1	42.7	-	30.9	32.5
200	-	58.5	54.6	47.3	56.6	51.2	47.4	51.2	48.2	40.4	42.0	42.5	30.3	31.8
208	-	54.2	51.8	41.4	53.7	49.3	44.4	50.4	47.1	39.7	41.3	41.7	29.7	31.1
216	-	49.3	49.1	35.0	50.9	47.1	40.4	49.4	45.7	39.1	40.6	41.1	29.1	30.5
224	-	-	46.8	-	47.4	44.8	35.4	47.1	43.5	37.3	39.8	40.4	28.5	29.8
232	-	-	-	-	42.7	-	-	44.6	41.3	34.7	39.0	39.7	27.8	29.2
240	-	-	-	-	40.8	-	-	41.8	39.3	30.5	38.4	39.0	27.3	28.6
248	-	-	-	-	-	-	-	37.3	37.4	26.2	37.7	37.7	26.8	28.0
256	-	-	-	-	-	-	-	35.7	37.0	35.9	37.0	37.7	26.2	27.3
264	-	-	-	-	-	-	-	34.3	32.8	34.2	32.8	34.2	22.7	26.9
272	-	-	-	-	-	-	-	-	-	32.5	-	26.5	27.1	26.5
280	-	-	-	-	-	-	-	-	-	31.0	-	25.9	26.6	25.9
288	-	-	-	-	-	-	-	-	-	-	-	24.4	26.2	26.0
296	-	-	-	-	-	-	-	-	-	-	-	-	25.8	25.8
304	-	-	-	-	-	-	-	-	-	-	-	-	-	18.3
312	-	-	-	-	-	-	-	-	-	-	-	-	-	17.9
320	-	-	-	-	-	-	-	-	-	-	-	-	-	18.1
328	-	-	-	-	-	-	-	-	-	-	-	-	-	17.7
336	-	-	-	-	-	-	-	-	-	-	-	-	-	-

Max. capacities with minimum counterweight · Further counterweight configurations on request

- 132,300 lb
- 176,400 lb
- 220,500 lb
- 264,600 lb
- 308,600 lb
- 352,700 lb

 360° 85%

 100.1 ft +  13.1 ft

ft	78.7 ft			98.4 ft			118.1 ft			137.8 ft			157.5 ft			177.2 ft		
	83°	73°	65°	83°	73°	65°	83°	73°	65°	83°	73°	65°	83°	73°	65°	83°	73°	65°
	1,000 lb																	
56	198.0	-	-	175.1	-	-	136.7	-	-	-	-	-	-	-	-	-	-	-
64	182.7	-	-	168.9	-	-	136.7	-	-	110.2	-	-	88.2	-	-	-	-	-
72	170.0	-	-	160.0	-	-	135.6	-	-	110.2	-	-	88.2	-	-	73.9	-	-
80	161.0	135.0	-	149.7	-	-	132.7	-	-	110.0	-	-	88.2	-	-	73.9	-	-
88	-	125.1	-	140.6	121.8	-	128.7	-	-	108.7	-	-	88.2	-	-	73.9	-	-
96	-	117.8	-	133.2	115.2	-	124.0	104.6	-	108.0	-	-	88.2	-	-	73.9	-	-
104	-	112.8	100.2	130.2	109.8	-	118.6	97.8	-	106.9	94.4	-	88.2	-	-	73.9	-	-
112	-	-	94.6	-	104.5	92.3	112.1	92.4	-	105.5	89.1	-	88.2	84.6	-	73.9	-	-
120	-	-	57.2	-	100.5	87.2	103.1	89.8	-	100.1	85.0	-	88.2	80.6	-	73.9	73.2	-
128	-	-	-	-	-	83.2	-	-	86.5	75.5	94.8	81.0	-	86.5	76.6	-	73.9	70.5
136	-	-	-	-	-	80.0	-	-	86.0	71.5	89.4	81.0	68.4	82.5	73.4	-	73.9	68.6
144	-	-	-	-	-	-	-	-	86.0	69.5	74.6	76.1	65.6	78.4	70.7	-	71.8	66.3
152	-	-	-	-	-	-	-	-	-	67.1	-	73.7	62.5	75.2	68.2	59.6	69.1	65.3
160	-	-	-	-	-	-	-	-	-	-	-	72.8	60.4	66.2	66.8	56.7	66.4	63.6
168	-	-	-	-	-	-	-	-	-	-	-	-	59.0	-	65.9	54.4	62.4	62.2
176	-	-	-	-	-	-	-	-	-	-	-	-	58.3	-	65.3	52.5	57.0	60.8
184	-	-	-	-	-	-	-	-	-	-	-	-	-	-	51.3	-	59.7	48.8
192	-	-	-	-	-	-	-	-	-	-	-	-	-	-	-	-	58.5	47.1
200	-	-	-	-	-	-	-	-	-	-	-	-	-	-	-	-	56.6	45.9
208	-	-	-	-	-	-	-	-	-	-	-	-	-	-	-	-	-	45.0
216	-	-	-	-	-	-	-	-	-	-	-	-	-	-	-	-	-	44.4

ft	196.9 ft			216.5 ft			236.2 ft			255.9 ft			275.6 ft			295.3 ft			315.0 ft		
	1,000 lb																				
80	66.1	-	-	51.4	-	-	-	-	-	-	-	-	-	-	-	-	-	-			
88	66.1	-	-	51.4	-	-	44.5	-	-	-	-	-	-	-	-	-	-	-			
96	66.1	-	-	51.4	-	-	44.5	-	-	38.8	-	-	31.3	-	-	-	-	-			
104	66.1	-	-	51.4	-	-	44.5	-	-	38.8	-	-	31.3	-	-	25.6	-	-			
112	66.1	-	-	51.4	-	-	44.5	-	-	38.8	-	-	31.3	-	-	25.1	-	19.6			
120	66.1	-	-	51.3	-	-	44.5	-	-	38.8	-	-	31.1	-	-	24.8	-	19.3			
128	66.1	61.9	-	51.1	-	-	44.5	-	-	38.7	-	-	31.1	-	-	24.6	-	18.8			
136	66.1	61.2	-	51.1	-	-	44.5	-	-	38.6	-	-	30.9	-	-	24.2	-	18.4			
144	65.9	60.2	-	50.9	55.6	-	44.5	-	-	38.4	-	-	30.7	-	-	23.8	-	18.1			
152	65.6	59.4	-	50.9	54.5	-	44.5	43.4	-	38.1	-	-	30.4	-	-	23.5	-	17.6			
160	63.6	58.5	-	50.7	53.2	-	44.5	43.2	-	37.8	37.8	-	30.1	-	-	23.1	-	17.2			
168	61.6	57.4	49.5	50.2	52.1	-	44.5	43.1	-	37.5	37.6	-	29.8	30.0	-	22.8	-	16.8			
176	59.6	56.4	48.1	49.3	50.9	-	44.3	43.0	-	37.1	37.3	-	29.4	29.6	-	22.3	23.4	16.4			
184	55.9	55.2	46.7	48.4	49.8	44.9	43.7	42.9	-	36.8	37.0	-	29.0	29.2	-	21.9	23.0	15.9			
192	50.9	54.0	45.4	47.4	48.7	43.0	43.0	42.7	39.9	36.5	36.7	-	28.6	28.8	-	21.5	22.6	15.6			
200	42.5	52.7	44.1	46.5	47.8	41.1	42.2	42.4	38.7	36.2	36.4	-	28.2	28.6	-	21.1	22.2	15.2			
208	-	51.4	42.8	42.7	46.9	39.7	41.4	42.0	37.4	35.7	35.9	33.9	27.8	28.2	-	20.8	21.8	14.8			
216	-	49.9	41.7	36.8	46.1	38.4	40.6	41.5	36.2	35.3	35.5	32.9	27.4	27.8	26.7	20.5	21.4	14.4			
224	-	-	40.7	-	45.2	37.7	36.2	40.9	35.3	34.9	35.1	32.0	27.0	27.5	26.0	20.2	21.1	14.0			
232	-	-	-	-	43.6	37.0	31.2	40.4	34.4	33.8	34.7	31.1	26.6	27.3	25.3	19.7	20.6	13.5			
240	-	-	-	-	-	36.3	-	39.9	33.7	31.0	34.1	30.4	26.2	27.0	24.5	19.4	20.2	13.1			
248	-	-	-	-	-	35.7	-	37.9	33.1	27.2	33.6	29.8	25.7	26.7	23.8	18.9	19.9	12.7			
256	-	-	-	-	-	-	-	32.4	-	33.1	29.1	25.1	26.5	23.1	18.5	19.6	19.2	12.3			
264	-	-	-	-	-	-	-	31.6	-	32.4	28.6	22.8	26.2	22.5	18.1	19.2	18.6	12.1			
272	-	-	-	-	-	-	-	-	-	30.4	28.0	19.9	25.9	21.8	17.8	18.8	18.1	11.8			
280	-	-	-	-	-	-	-	-	-	-	27.5	-	25.6	21.3	17.5	18.4	17.7	11.4			
288	-	-	-	-	-	-	-	-	-	-	27.1	-	24.9	20.8	15.8	18.0	17.2	11.1			
296	-	-	-	-	-	-	-	-	-	-	-	-	20.2	-	17.6	16.7	11.0	11.7			
304	-	-	-	-	-	-	-	-	-	-	-	-	19.8	-	17.3	16.3	10.7	11.4			
312	-	-	-	-	-	-	-	-	-	-	-	-	-	-	17.0	15.9	10.2	11.1			
320	-	-	-	-	-	-	-	-	-	-	-	-	-	-	-	15.3	-	10.9			
328	-	-	-	-	-	-	-	-	-	-	-	-	-	-	-	14.9	-	10.7			
336	-	-	-	-	-	-	-	-	-	-	-	-	-	-	-	-	-	10.5			
344	-	-	-	-	-	-	-	-	-	-	-	-	-	-	-	-	-	10.3			

Max. capacities with minimum counterweight - Further counterweight configurations on request

-  132,300 lb
-  176,400 lb
-  220,500 lb
-  264,600 lb
-  308,600 lb
-  352,700 lb

 **360°** **85%**



ft	78.7 ft			98.4 ft			118.1 ft			137.8 ft			157.5 ft			177.2 ft		
	83°	73°	65°	83°	73°	65°	83°	73°	65°	83°	73°	65°	83°	73°	65°	83°	73°	65°
	1,000 lb																	
56	174.4	-	-	147.6	-	-	120.2	-	-	-	-	-	-	-	-	-	-	-
64	162.3	-	-	144.4	-	-	120.2	-	-	99.2	-	-	-	-	-	-	-	-
72	150.2	-	-	137.9	-	-	120.2	-	-	99.2	-	-	78.3	-	-	-	-	-
80	141.1	-	-	131.2	-	-	117.5	-	-	99.2	-	-	78.3	-	-	66.1	-	-
88	-	109.1	-	125.0	-	-	114.4	-	-	98.8	-	-	78.3	-	-	66.1	-	-
96	-	102.3	-	120.3	96.8	-	111.0	-	-	98.1	-	-	78.3	-	-	66.1	-	-
104	-	97.5	-	118.1	91.1	-	109.3	87.7	-	97.2	-	-	78.3	-	-	66.1	-	-
112	-	-	80.2	-	86.9	-	106.8	82.4	-	95.8	80.2	-	78.3	-	-	66.1	-	-
120	-	-	75.9	-	83.1	71.0	104.2	78.4	-	94.5	76.2	-	78.3	72.1	-	66.1	-	-
128	-	-	49.3	-	54.9	67.8	-	74.9	66.1	92.6	72.2	-	77.7	68.9	-	66.1	64.9	-
136	-	-	-	-	-	65.0	-	73.1	62.4	90.7	68.9	-	77.2	66.0	-	66.1	62.1	-
144	-	-	-	-	-	63.1	-	72.8	59.4	79.0	66.3	56.6	76.1	63.6	-	65.9	59.8	-
152	-	-	-	-	-	-	-	-	56.9	-	64.8	53.5	74.8	61.1	51.4	65.7	57.5	-
160	-	-	-	-	-	-	-	-	55.4	-	63.3	51.0	69.7	59.4	48.5	65.3	55.6	-
168	-	-	-	-	-	-	-	-	-	-	49.2	-	-	58.0	46.1	63.1	53.9	44.1
176	-	-	-	-	-	-	-	-	-	-	48.0	-	-	57.0	44.0	59.2	52.5	41.8
184	-	-	-	-	-	-	-	-	-	-	24.0	-	-	27.9	42.6	-	51.4	40.0
192	-	-	-	-	-	-	-	-	-	-	-	-	-	41.6	-	50.6	38.3	-
200	-	-	-	-	-	-	-	-	-	-	-	-	-	41.0	-	49.9	36.9	-
208	-	-	-	-	-	-	-	-	-	-	-	-	-	-	-	-	-	35.9
216	-	-	-	-	-	-	-	-	-	-	-	-	-	-	-	-	-	35.1
224	-	-	-	-	-	-	-	-	-	-	-	-	-	-	-	-	-	13.3

ft	196.9 ft			216.5 ft			236.2 ft			255.9 ft			275.6 ft			295.3 ft			315.0 ft		
	1,000 lb																				
80	59.5	-	-	-	-	-	-	-	-	-	-	-	-	-	-	-	-	-			
88	59.5	-	-	46.3	-	-	-	-	-	-	-	-	-	-	-	-	-	-			
96	59.5	-	-	46.3	-	-	40.8	-	-	35.3	-	-	-	-	-	-	-	-			
104	59.5	-	-	46.3	-	-	40.8	-	-	35.3	-	-	28.7	-	-	-	-	-			
112	59.5	-	-	46.3	-	-	40.8	-	-	35.3	-	-	28.7	-	-	24.0	-	-			
120	59.5	-	-	46.3	-	-	40.8	-	-	35.3	-	-	28.7	-	-	24.0	-	-			
128	59.5	-	-	46.3	-	-	40.8	-	-	35.3	-	-	28.7	-	-	23.8	-	-			
136	59.5	54.6	-	46.3	-	-	40.8	-	-	35.3	-	-	28.7	-	-	23.6	-	-			
144	59.5	53.0	-	46.3	-	-	40.8	-	-	35.3	-	-	28.7	-	-	23.4	-	-			
152	59.5	51.6	-	46.3	52.0	-	40.8	39.7	-	35.3	-	-	28.7	-	-	23.1	-	-			
160	59.1	50.3	-	46.3	49.8	-	40.8	39.6	-	35.3	-	-	28.7	-	-	23.1	-	-			
168	58.6	49.0	-	46.3	47.8	-	40.8	39.4	-	35.3	33.7	-	28.7	-	-	22.8	-	-			
176	58.2	47.8	41.2	46.3	45.9	-	40.8	39.3	-	35.3	33.7	-	28.7	27.6	-	22.5	-	-			
184	56.3	46.7	39.6	46.3	44.4	-	40.8	39.0	-	35.3	33.7	-	28.7	27.6	-	22.3	23.0	-			
192	52.7	45.7	38.0	46.3	42.9	36.8	40.8	38.7	-	35.3	33.7	-	28.7	27.6	-	22.0	22.7	-			
200	44.7	44.7	36.6	46.3	41.6	34.8	40.8	38.4	-	35.3	33.7	-	28.7	27.6	-	21.7	22.4	-			
208	-	43.9	35.2	43.4	40.5	33.0	40.8	37.9	31.9	35.1	33.7	-	28.5	27.6	-	21.5	22.1	-			
216	-	43.3	34.0	38.3	39.5	31.4	40.8	37.5	30.3	35.1	33.7	28.5	28.2	27.6	-	21.2	21.8	-			
224	-	18.1	33.1	-	38.8	30.2	36.9	37.0	28.8	35.1	33.4	27.4	27.7	27.6	23.9	20.8	21.6	-			
232	-	-	32.2	-	38.2	29.1	32.3	36.4	27.5	34.3	33.0	26.4	27.4	27.5	22.9	20.5	21.4	-			
240	-	-	31.4	-	37.8	28.5	26.8	35.7	26.4	31.8	32.5	25.3	26.9	27.2	22.1	20.2	21.1	20.5			
248	-	-	-	-	-	28.0	-	35.1	25.5	28.1	32.1	24.4	26.4	26.9	21.3	19.9	20.8	19.9			
256	-	-	-	-	-	-	9.5	24.7	-	-	31.7	23.6	26.0	26.5	20.5	19.6	20.5	19.4			
264	-	-	-	-	-	-	8.8	24.1	-	-	31.3	22.9	23.4	26.0	19.8	19.2	20.2	18.7			
272	-	-	-	-	-	-	-	23.7	-	-	30.3	22.3	20.4	25.7	19.1	18.9	19.9	18.1			
280	-	-	-	-	-	-	-	23.4	-	-	28.3	21.7	-	25.4	18.4	18.6	19.5	17.6			
288	-	-	-	-	-	-	-	-	-	-	21.3	-	-	25.1	17.8	16.7	19.2	17.0			
296	-	-	-	-	-	-	-	-	-	-	-	-	-	5.5	17.1	-	18.9	16.5			
304	-	-	-	-	-	-	-	-	-	-	-	-	-	4.9	16.6	-	18.5	15.9			
312	-	-	-	-	-	-	-	-	-	-	-	-	-	-	16.1	-	18.2	15.4			
320	-	-	-	-	-	-	-	-	-	-	-	-	-	-	15.5	-	17.9	14.7			
328	-	-	-	-	-	-	-	-	-	-	-	-	-	-	-	-	14.1	-			
336	-	-	-	-	-	-	-	-	-	-	-	-	-	-	-	-	-	-			
344	-	-	-	-	-	-	-	-	-	-	-	-	-	-	-	-	-	-			
352	-	-	-	-	-	-	-	-	-	-	-	-	-	-	-	-	-	10.6			

360° **85%**

132.9 ft + 13.1 ft

ft	78.7 ft			98.4 ft			118.1 ft			137.8 ft			157.5 ft			177.2 ft			
	83°	73°	65°	83°	73°	65°	83°	73°	65°	83°	73°	65°	83°	73°	65°	83°	73°	65°	
56	144.4	-	-	123.5	-	-	-	-	-	-	-	-	-	-	-	-	-	-	
64	140.2	-	-	123.5	-	-	94.8	-	-	-	-	-	-	-	-	-	-	-	
72	132.5	-	-	121.3	-	-	94.8	-	-	78.3	-	-	64.4	-	-	-	-	-	
80	123.3	-	-	113.6	-	-	94.4	-	-	78.3	-	-	64.4	-	-	55.6	-	-	
88	-	-	-	107.3	-	-	91.7	-	-	78.3	-	-	64.4	-	-	55.6	-	-	
96	-	88.0	-	103.0	87.3	-	89.7	-	-	78.3	-	-	64.4	-	-	55.6	-	-	
104	-	83.2	-	100.5	81.1	-	88.4	-	-	77.3	-	-	64.4	-	-	55.6	-	-	
112	-	65.8	-	-	75.8	-	87.0	68.1	-	77.2	-	-	64.4	-	-	55.6	-	-	
120	-	-	64.6	-	71.8	-	85.7	64.6	-	76.1	62.6	-	64.3	-	-	55.5	-	-	
128	-	-	60.1	-	69.4	59.3	-	61.5	-	75.5	59.2	-	64.0	56.5	-	55.3	-	-	
136	-	-	43.1	-	48.7	55.9	-	59.2	-	74.2	56.2	-	63.6	53.6	-	55.3	50.9	-	
144	-	-	-	-	-	53.0	-	57.8	48.0	72.8	53.9	-	63.3	51.0	-	55.1	48.6	-	
152	-	-	-	-	-	34.5	-	40.4	45.4	-	51.8	43.4	62.7	48.7	-	55.1	46.3	-	
160	-	-	-	-	-	-	-	-	43.7	-	50.6	41.2	62.0	46.9	-	54.7	44.4	-	
168	-	-	-	-	-	-	-	-	28.1	-	33.0	39.3	-	45.3	36.9	54.4	42.7	-	
176	-	-	-	-	-	-	-	-	26.1	-	30.8	37.7	-	44.0	34.9	54.1	41.2	33.7	
184	-	-	-	-	-	-	-	-	-	-	-	36.8	-	43.3	33.3	-	40.1	32.0	
192	-	-	-	-	-	-	-	-	-	-	-	-	-	-	32.0	-	39.1	30.4	
200	-	-	-	-	-	-	-	-	-	-	-	-	-	-	31.0	-	38.4	29.0	
208	-	-	-	-	-	-	-	-	-	-	-	-	-	-	-	15.3	-	19.6	27.9
216	-	-	-	-	-	-	-	-	-	-	-	-	-	-	-	14.2	-	18.4	27.0
224	-	-	-	-	-	-	-	-	-	-	-	-	-	-	-	-	-	-	26.4

ft	196.9 ft			216.5 ft			236.2 ft			255.9 ft			275.6 ft			295.3 ft			315.0 ft		
	1,000 lb																				
80	48.3	-	-	-	-	-	-	-	-	-	-	-	-	-	-	-	-	-	-	-	
88	48.3	-	-	37.5	-	-	-	-	-	-	-	-	-	-	-	-	-	-	-	-	
96	48.3	-	-	37.5	-	-	31.5	-	-	27.8	-	-	-	-	-	-	-	-	-	-	
104	48.3	-	-	37.5	-	-	31.5	-	-	27.8	-	-	22.0	-	-	-	-	-	-	-	
112	48.3	-	-	37.5	-	-	31.5	-	-	27.6	-	-	22.0	-	-	18.3	-	-	-	-	
120	48.3	-	-	37.5	-	-	31.5	-	-	27.5	-	-	22.0	-	-	18.2	-	-	13.8	-	
128	48.3	-	-	37.5	-	-	31.5	-	-	27.3	-	-	22.0	-	-	18.1	-	-	13.6	-	
136	48.3	-	-	37.5	-	-	31.5	-	-	27.3	-	-	22.0	-	-	18.1	-	-	13.1	-	
144	48.3	43.3	-	37.5	-	-	31.5	-	-	27.3	-	-	22.0	-	-	18.1	-	-	12.8	-	
152	48.3	41.9	-	37.5	41.9	-	31.5	-	-	27.3	-	-	22.0	-	-	17.9	-	-	12.5	-	
160	48.2	40.6	-	37.5	40.3	-	31.5	-	-	27.3	-	-	22.0	-	-	17.8	-	-	12.3	-	
168	47.9	39.3	-	37.5	38.7	-	31.5	30.1	-	27.3	-	-	22.0	-	-	17.6	-	-	12.0	-	
176	47.7	38.1	-	37.5	37.3	-	31.5	29.8	-	27.3	27.6	-	22.0	-	-	17.6	-	-	11.7	-	
184	47.4	37.2	31.0	37.5	35.7	-	31.5	29.5	-	27.3	27.2	-	22.0	20.9	-	17.5	-	-	11.5	-	
192	46.7	36.2	29.7	37.5	34.2	-	31.5	29.3	-	27.3	26.8	-	22.0	20.9	-	17.4	-	-	11.2	-	
200	44.2	35.4	28.4	37.5	33.1	27.5	31.5	29.0	-	27.2	26.6	-	22.0	20.9	-	17.3	17.2	-	10.9	11.8	
208	-	34.7	27.2	37.5	32.2	26.0	31.5	28.6	24.5	27.1	26.2	-	22.0	20.9	-	17.1	17.1	-	10.6	11.5	
216	-	34.0	26.1	37.5	31.6	24.6	31.5	28.2	23.0	27.1	25.8	-	21.8	20.9	-	17.0	17.0	-	10.4	11.3	
224	-	33.4	25.1	-	30.9	23.2	31.5	27.7	21.8	27.1	25.4	19.2	21.7	20.9	-	16.9	16.9	-	10.2	11.0	
232	-	-	24.3	-	30.2	22.1	30.6	27.2	20.6	27.1	25.0	18.2	21.5	20.9	16.7	16.7	16.7	-	10.1	10.8	
240	-	-	23.6	-	29.6	21.6	27.4	26.6	19.2	27.1	24.6	17.3	21.3	20.9	15.9	16.4	16.6	-	9.8	10.6	
248	-	-	8.4	-	11.2	21.0	-	26.2	18.5	26.1	24.2	16.5	21.1	20.8	15.2	16.2	16.4	14.7	9.6	10.4	
256	-	-	-	-	-	20.5	-	25.8	18.1	-	23.8	15.9	20.9	20.5	14.5	16.1	16.1	13.9	9.5	10.1	
264	-	-	-	-	-	20.0	-	25.3	17.5	-	23.4	15.3	20.7	20.4	13.9	16.0	16.0	13.3	9.3	10.0	
272	-	-	-	-	-	-	-	17.0	-	22.9	14.8	19.5	20.2	13.2	15.8	15.8	12.8	9.2	9.8	-	
280	-	-	-	-	-	-	-	16.6	-	22.4	14.3	16.8	20.1	12.5	15.7	15.5	12.1	9.1	9.6	-	
288	-	-	-	-	-	-	-	-	-	22.4	13.9	-	20.0	12.1	15.3	15.2	11.5	8.9	9.4	-	
296	-	-	-	-	-	-	-	-	-	-	13.7	-	19.8	11.6	-	15.0	11.0	8.8	9.2	-	
304	-	-	-	-	-	-	-	-	-	-	13.5	-	19.5	11.2	-	14.7	10.6	8.7	9.1	-	
312	-	-	-	-	-	-	-	-	-	-	-	-	-	10.9	-	14.4	10.1	8.5	9.0	-	
320	-	-	-	-	-	-	-	-	-	-	-	-	-	10.6	-	14.2	9.6	8.4	8.8	-	
328	-	-	-	-	-	-	-	-	-	-	-	-	-	-	-	-	9.3	-	8.7	-	
336	-	-	-	-	-	-	-	-	-	-	-	-	-	-	-	-	9.0	-	8.6	-	
344	-	-	-	-	-	-	-	-	-	-	-	-	-	-	-	-	8.6	-	8.4	-	

Max. capacities with minimum counterweight - Further counterweight configurations on request

360°													85%					
149.3 ft + 13.1 ft																		
ft	78.7 ft			98.4 ft			118.1 ft			137.8 ft			157.5 ft			177.2 ft		
	83°	73°	65°	83°	73°	65°	83°	73°	65°	83°	73°	65°	83°	73°	65°	83°	73°	65°
ft	1,000 lb																	
64	114.1	-	-	99.2	-	-	-	-	-	-	-	-	-	-	-	-	-	-
72	109.2	-	-	99.2	-	-	79.4	-	-	66.1	-	-	-	-	-	-	-	-
80	102.6	-	-	95.1	-	-	79.2	-	-	66.1	-	-	57.3	-	-	50.7	-	-
88	96.3	-	-	90.6	-	-	78.3	-	-	66.1	-	-	57.3	-	-	50.7	-	-
96	-	-	-	86.8	-	-	77.2	-	-	66.1	-	-	57.3	-	-	50.7	-	-
104	-	-	-	85.0	-	-	76.2	-	-	66.1	-	-	57.1	-	-	50.7	-	-
112	-	67.1	-	-	63.7	-	75.0	60.4	-	66.1	-	-	57.1	-	-	50.7	-	-
120	-	-	-	-	60.3	-	74.6	56.7	-	66.1	-	-	56.8	-	-	50.6	-	-
128	-	-	50.5	-	57.5	-	73.9	53.6	-	65.9	51.2	-	56.5	-	-	50.5	-	-
136	-	-	47.2	-	55.4	45.6	-	51.0	-	65.5	48.3	-	56.3	46.1	-	50.5	-	-
144	-	-	37.2	-	-	43.3	-	49.2	-	65.1	46.0	-	55.8	43.5	-	50.3	42.2	-
152	-	-	-	-	-	41.2	-	48.0	38.1	-	43.7	-	55.5	41.2	-	50.2	39.9	-
160	-	-	-	-	-	29.7	-	-	36.2	-	42.3	-	55.0	39.1	-	50.0	37.9	-
168	-	-	-	-	-	-	-	-	34.7	-	41.0	33.0	-	37.3	-	49.6	36.0	-
176	-	-	-	-	-	-	-	-	33.7	-	40.0	31.5	-	35.9	28.9	49.2	34.4	-
184	-	-	-	-	-	-	-	-	-	-	-	30.3	-	34.9	27.4	47.5	33.0	26.8
192	-	-	-	-	-	-	-	-	-	-	-	18.0	-	-	26.0	-	32.0	25.3
200	-	-	-	-	-	-	-	-	-	-	-	16.8	-	-	24.8	-	31.0	23.9
208	-	-	-	-	-	-	-	-	-	-	-	-	-	-	23.8	-	30.4	22.8
216	-	-	-	-	-	-	-	-	-	-	-	-	-	-	23.0	-	30.0	21.9
224	-	-	-	-	-	-	-	-	-	-	-	-	-	-	-	-	-	21.1
232	-	-	-	-	-	-	-	-	-	-	-	-	-	-	-	-	-	8.4
240	-	-	-	-	-	-	-	-	-	-	-	-	-	-	-	-	-	7.7

ft	196.9 ft			216.5 ft			236.2 ft			255.9 ft			275.6 ft			295.3 ft			315.0 ft		
	1,000 lb																				
88	41.9	-	-	-	-	-	-	-	-	-	-	-	-	-	-	-	-	-	-	-	
96	41.9	-	-	32.4	-	-	25.4	-	-	-	-	-	-	-	-	-	-	-	-	-	
104	41.9	-	-	32.4	-	-	25.4	-	-	23.2	-	-	-	-	-	-	-	-	-	-	
112	41.9	-	-	32.4	-	-	25.4	-	-	22.9	-	-	17.6	-	-	-	-	-	-	-	
120	41.9	-	-	32.4	-	-	25.4	-	-	22.6	-	-	17.6	-	-	14.3	-	-	10.7	-	
128	41.9	-	-	32.4	-	-	25.4	-	-	22.5	-	-	17.6	-	-	14.3	-	-	10.4	-	
136	41.9	-	-	32.4	-	-	25.4	-	-	22.3	-	-	17.6	-	-	14.3	-	-	10.0	-	
144	41.9	-	-	32.4	-	-	25.4	-	-	22.1	-	-	17.6	-	-	14.3	-	-	9.7	-	
152	41.9	36.9	-	32.4	-	-	25.4	-	-	22.0	-	-	17.6	-	-	14.3	-	-	9.4	-	
160	41.9	35.5	-	32.4	-	-	25.4	-	-	22.0	-	-	17.6	-	-	14.3	-	-	9.2	-	
168	41.9	34.2	-	32.4	32.1	-	25.4	24.2	-	22.0	-	-	17.6	-	-	14.3	-	-	8.9	-	
176	41.9	33.0	-	32.4	30.6	-	25.4	23.9	-	22.0	-	-	17.6	-	-	14.3	-	-	8.6	-	
184	41.9	31.9	-	32.4	29.4	-	25.4	23.6	-	22.0	24.2	-	17.6	16.5	-	14.3	-	-	8.5	-	
192	41.9	30.9	-	32.4	28.2	-	25.4	23.3	-	22.0	23.4	-	17.6	16.5	-	14.3	-	-	8.3	-	
200	41.9	29.9	23.2	32.4	27.1	-	25.4	22.9	-	22.0	22.6	-	17.6	16.5	-	14.3	-	-	8.2	-	
208	41.9	29.1	22.0	32.4	26.1	20.3	25.4	22.5	-	22.0	21.8	-	17.6	16.5	-	14.3	13.2	-	8.1	8.7	
216	-	28.3	20.8	32.4	25.2	19.0	25.4	22.1	-	22.0	21.0	-	17.6	16.5	-	14.3	13.2	-	7.9	8.6	
224	-	27.7	19.8	30.4	24.4	17.8	25.4	21.7	16.2	22.0	20.3	-	17.6	16.5	-	14.3	13.2	-	7.8	8.5	
232	-	-	19.0	-	23.7	16.7	25.4	21.3	14.9	22.0	19.6	11.7	17.6	16.5	-	14.3	13.2	-	7.7	8.3	
240	-	-	18.3	-	23.1	15.9	25.4	20.9	13.8	22.0	19.0	10.9	17.6	16.5	11.6	14.3	13.2	-	7.7	8.2	
248	-	-	17.6	-	22.7	15.2	-	20.4	12.9	22.0	18.4	10.1	17.6	16.4	10.7	14.3	13.1	-	7.6	8.1	
256	-	-	-	-	-	14.5	-	19.8	12.1	22.0	17.9	9.5	17.6	16.1	9.9	14.3	13.0	10.6	7.5	7.9	
264	-	-	-	-	-	14.0	-	19.2	11.4	19.1	17.3	8.9	17.6	15.7	9.1	14.3	12.9	9.6	7.5	7.8	
272	-	-	-	-	-	-	-	10.9	-	16.8	8.5	17.4	15.3	8.4	14.3	12.7	8.8	7.4	7.7	-	
280	-	-	-	-	-	-	-	10.5	-	16.4	8.2	16.9	15.1	7.9	14.3	12.6	8.1	7.3	7.5	-	
288	-	-	-	-	-	-	-	10.2	-	16.0	7.9	-	14.7	7.4	14.3	12.5	7.4	7.3	7.5	-	
296	-	-	-	-	-	-	-	-	-	-	7.5	-	14.3	7.0	14.0	12.3	6.8	7.3	7.5	-	
304	-	-	-	-	-	-	-	-	-	-	7.3	-	13.9	6.6	11.0	12.2	6.2	7.1	7.3	-	
312	-	-	-	-	-	-	-	-	-	-	-	-	-	6.3	-	12.1	5.8	6.9	7.2	-	
320	-	-	-	-	-	-	-	-	-	-	-	-	-	6.2	-	11.9	5.4	6.7	7.1	-	
328	-	-	-	-	-	-	-	-	-	-	-	-	-	6.2	-	11.6	5.0	-	6.9	-	
336	-	-	-	-	-	-	-	-	-	-	-	-	-	-	-	-	4.8	-	6.8	-	
344	-	-	-	-	-	-	-	-	-	-	-	-	-	-	-	-	4.5	-	6.7	-	

Max. capacities with minimum counterweight · Further counterweight configurations on request

360°													85%														
165.7 ft + 13.1 ft																											
78.7 ft													98.4 ft			118.1 ft			137.8 ft			157.5 ft			177.2 ft		
83° 73° 65°													83° 73° 65°			83° 73° 65°			83° 73° 65°			83° 73° 65°			83° 73° 65°		
ft	1,000 lb																										
64	83.8	-	-	72.2	-	-	-	-	-	-	-	-	-	-	-	-	-	-	-	-	-	-					
72	82.7	-	-	69.5	-	-	58.6	-	-	-	-	-	-	-	-	-	-	-	-	-	-	-					
80	80.3	-	-	68.3	-	-	58.6	-	-	48.7	-	-	44.5	-	-	-	-	-	-	-	-	-					
88	78.5	-	-	68.3	-	-	58.5	-	-	48.7	-	-	44.5	-	-	37.7	-	-	-	-	-	-					
96	-	-	-	68.3	-	-	57.9	-	-	48.7	-	-	44.5	-	-	37.7	-	-	-	-	-	-					
104	-	-	-	67.4	-	-	57.6	-	-	48.7	-	-	44.3	-	-	37.7	-	-	-	-	-	-					
112	-	56.1	-	-	54.1	-	57.1	-	-	48.7	-	-	44.1	-	-	37.7	-	-	-	-	-	-					
120	-	53.2	-	-	51.1	-	56.9	-	-	48.7	-	-	43.5	-	-	37.5	-	-	-	-	-	-					
128	-	-	-	-	48.4	-	56.5	42.5	-	48.7	-	-	43.1	-	-	37.5	-	-	-	-	-	-					
136	-	-	-	-	46.0	-	-	40.4	-	48.6	38.0	-	42.7	-	-	37.5	-	-	-	-	-	-					
144	-	-	35.2	-	44.2	-	-	38.7	-	48.3	36.0	-	42.1	33.8	-	37.5	-	-	-	-	-	-					
152	-	-	-	-	-	35.0	-	37.1	-	-	34.2	-	41.8	31.7	-	37.4	30.4	-	-	-	-	-					
160	-	-	-	-	-	33.1	-	36.3	29.0	-	32.8	-	41.4	30.1	-	37.2	28.8	-	-	-	-	-					
168	-	-	-	-	-	-	-	-	27.6	-	31.6	-	-	28.5	-	36.9	27.3	-	-	-	-	-					
176	-	-	-	-	-	-	-	-	26.4	-	30.8	24.4	-	27.3	-	36.6	26.0	-	-	-	-	-					
184	-	-	-	-	-	-	-	-	20.6	-	-	23.3	-	26.3	21.0	36.5	24.9	-	-	-	-	-					
192	-	-	-	-	-	-	-	-	-	-	-	22.3	-	25.5	19.8	-	23.8	-	-	-	-	-					
200	-	-	-	-	-	-	-	-	-	-	-	21.5	-	24.9	18.8	-	23.0	17.9	-	-	-	-					
208	-	-	-	-	-	-	-	-	-	-	-	-	-	-	17.8	-	22.4	16.9	-	-	-	-					
216	-	-	-	-	-	-	-	-	-	-	-	-	-	-	17.0	-	21.9	15.9	-	-	-	-					
224	-	-	-	-	-	-	-	-	-	-	-	-	-	-	9.7	-	-	15.1	-	-	-	-					
232	-	-	-	-	-	-	-	-	-	-	-	-	-	-	-	-	-	14.4	-	-	-	-					
240	-	-	-	-	-	-	-	-	-	-	-	-	-	-	-	-	-	14.0	-	-	-	-					

196.9 ft													216.5 ft			236.2 ft			255.9 ft			275.6 ft			295.3 ft			315.0 ft		
ft	1,000 lb																													
88	29.8	-	-	-	-	-	-	-	-	-	-	-	-	-	-	-	-	-	-	-	-	-								
96	29.8	-	-	22.7	-	-	-	-	-	-	-	-	-	-	-	-	-	-	-	-	-	-								
104	29.8	-	-	22.7	-	-	17.2	-	-	-	-	-	-	-	-	-	-	-	-	-	-	-								
112	29.8	-	-	22.7	-	-	17.2	-	-	14.3	-	-	10.6	-	-	-	-	-	-	-	-	-								
120	29.8	-	-	22.7	-	-	17.2	-	-	14.3	-	-	10.6	-	-	-	-	-	-	-	-	-								
128	29.8	-	-	22.7	-	-	17.2	-	-	14.2	-	-	10.6	-	-	-	-	-	-	-	-	-								
136	29.8	-	-	22.7	-	-	17.2	-	-	14.1	-	-	10.6	-	-	-	-	-	-	-	-	-								
144	29.8	-	-	22.7	-	-	17.2	-	-	14.1	-	-	10.6	-	-	-	-	-	-	-	-	-								
152	29.8	-	-	22.7	-	-	17.2	-	-	13.9	-	-	10.6	-	-	-	-	-	-	-	-	-								
160	29.8	26.3	-	22.7	-	-	17.2	-	-	13.9	-	-	10.6	-	-	-	-	-	-	-	-	-								
168	29.8	25.3	-	22.7	22.6	-	17.2	-	-	13.9	-	-	10.6	-	-	-	-	-	-	-	-	-								
176	29.8	24.2	-	22.7	21.7	-	17.2	16.5	-	13.9	-	-	10.6	-	-	-	-	-	-	-	-	-								
184	29.8	23.1	-	22.7	20.7	-	17.2	16.2	-	13.9	-	-	10.6	-	-	-	-	-	-	-	-	-								
192	29.8	22.1	-	22.7	19.6	-	17.2	15.8	-	13.9	-	-	10.6	-	-	-	-	-	-	-	-	-								
200	29.8	21.3	-	22.7	18.7	-	17.2	15.5	-	13.9	-	-	10.6	-	-	-	-	-	-	-	-	-								
208	-	20.6	15.8	22.7	17.8	-	17.2	15.2	-	13.9	-	-	10.6	-	-	-	-	-	-	-	-	-								
216	-	20.1	14.8	22.7	17.0	-	17.2	14.8	-	13.9	-	-	10.6	-	-	-	-	-	-	-	-	-								
224	-	19.6	14.0	22.7	16.5	-	17.2	14.4	-	13.9	-	-	10.6	-	-	-	-	-	-	-	-	-								
232	-	19.1	13.3	-	15.9	-	17.2	14.0	-	13.9	-	-	10.6	-	-	-	-	-	-	-	-	-								
240	-	18.7	12.6	-	15.4	-	17.2	13.8	-	13.9	-	-	10.6	-	-	-	-	-	-	-	-	-								
248	-	-	12.1	-	14.9	-	-	13.4	-	13.9	-	-	10.6	-	-	-	-	-	-	-	-	-								
256	-	-	-	-	-	-	-	13.0	-	13.9	-	-	10.6	-	-	-	-	-	-	-	-	-								
264	-	-	-	-	-	-	-	12.7	-	13.9	-	-	10.6	-	-	-	-	-	-	-	-	-								
272	-	-	-	-	-	-	-	12.4	-	-	-	-	10.6	-	-	-	-	-	-	-	-	-								
280	-	-	-	-	-	-	-	12.0	-	-	-	-	10.6	-	-	-	-	-	-	-	-	-								

Max. capacities with minimum counterweight · Further counterweight configurations on request

- 132,300 lb
- 176,400 lb
- 220,500 lb
- 264,600 lb
- 308,600 lb
- 352,700 lb

360°															85%			
182.1 ft + 13.1 ft																		
ft	78.7 ft			98.4 ft			118.1 ft			137.8 ft			157.5 ft			177.2 ft		
	83°	73°	65°	83°	73°	65°	83°	73°	65°	83°	73°	65°	83°	73°	65°	83°	73°	65°
	1,000 lb																	
72	68.3	-	-	56.2	-	-	-	-	-	-	-	-	-	-	-	-	-	-
80	65.9	-	-	56.1	-	-	44.1	-	-	36.6	-	-	-	-	-	-	-	-
88	64.4	-	-	55.1	-	-	44.1	-	-	36.6	-	-	36.4	-	-	-	-	-
96	-	-	-	53.9	-	-	44.1	-	-	36.6	-	-	36.4	-	-	28.4	-	-
104	-	-	-	52.8	-	-	44.1	-	-	36.6	-	-	36.2	-	-	28.4	-	-
112	-	-	-	-	-	-	44.1	-	-	36.6	-	-	35.9	-	-	28.4	-	-
120	-	44.1	-	-	39.8	-	44.1	-	-	36.6	-	-	35.1	-	-	28.4	-	-
128	-	41.9	-	-	37.6	-	44.1	34.8	-	36.6	-	-	34.4	-	-	28.4	-	-
136	-	-	-	-	35.7	-	-	33.1	-	36.6	-	-	33.7	-	-	28.4	-	-
144	-	-	-	-	34.4	-	-	31.6	-	36.6	29.2	-	33.1	-	-	28.4	-	-
152	-	-	30.4	-	-	-	-	30.3	-	-	27.6	-	32.6	25.0	-	28.4	-	-
160	-	-	-	-	26.4	-	29.4	-	-	-	26.3	-	32.1	23.5	-	28.4	22.1	-
168	-	-	-	-	24.0	-	-	-	-	-	25.3	-	-	22.2	-	28.2	20.8	-
176	-	-	-	-	22.3	-	-	21.7	-	-	24.4	-	-	21.1	-	28.0	19.6	-
184	-	-	-	-	-	-	-	20.8	-	-	23.6	18.3	-	20.1	-	27.9	18.6	-
192	-	-	-	-	-	-	-	-	-	-	-	17.5	-	19.3	-	-	17.7	-
200	-	-	-	-	-	-	-	-	-	-	-	16.7	-	18.7	13.8	-	17.0	-
208	-	-	-	-	-	-	-	-	-	-	-	12.5	-	-	13.3	-	16.4	12.1
216	-	-	-	-	-	-	-	-	-	-	-	11.5	-	-	12.6	-	15.9	11.3
224	-	-	-	-	-	-	-	-	-	-	-	-	-	12.1	-	13.2	-	10.6
232	-	-	-	-	-	-	-	-	-	-	-	-	-	-	-	-	-	10.0
240	-	-	-	-	-	-	-	-	-	-	-	-	-	-	-	-	-	9.4

ft	196.9 ft		216.5 ft		236.2 ft		255.9 ft		275.6 ft		295.3 ft		315.0 ft	
	83°	73°	83°	73°	83°	73°	83°	73°	83°	73°	83°	73°	83°	73°
	1,000 lb													
96	20.9	-	15.4	-	-	-	-	-	-	-	-	-	-	-
104	20.9	-	15.4	-	-	-	-	-	-	-	-	-	-	-
112	20.9	-	15.4	-	11.0	-	7.3	-	-	-	-	-	-	-
120	20.9	-	15.4	-	11.0	-	7.3	-	4.4	-	-	-	-	-
128	20.9	-	15.4	-	11.0	-	7.3	-	4.4	-	-	-	-	-
136	20.9	-	15.4	-	11.0	-	7.3	-	4.4	-	-	-	-	-
144	20.9	-	15.4	-	11.0	-	7.3	-	4.4	-	-	-	-	-
152	20.9	-	15.4	-	11.0	-	7.3	-	4.4	-	-	-	-	-
160	20.9	-	15.4	-	11.0	-	7.3	-	4.4	-	-	-	-	-
168	20.9	18.9	15.4	-	11.0	-	7.3	-	4.4	-	-	-	-	-
176	20.9	17.8	15.4	13.8	11.0	-	7.3	-	4.4	-	-	-	-	-
184	20.9	16.9	15.4	13.0	11.0	10.6	7.3	-	4.4	-	-	-	-	-
192	20.9	16.1	15.4	12.2	11.0	10.2	7.3	-	4.4	-	-	-	-	-
200	20.9	15.3	15.4	11.5	11.0	9.7	7.3	-	4.4	-	-	-	-	-
208	-	14.6	15.4	10.9	11.0	9.2	7.3	-	4.4	-	-	-	-	-
216	-	13.9	15.4	10.2	11.0	8.8	7.3	-	4.4	-	-	-	-	-
224	-	13.5	15.4	9.5	11.0	8.6	7.3	-	4.4	-	-	-	-	-
232	-	13.1	15.4	8.9	11.0	8.3	7.3	-	4.4	-	-	-	-	-
240	-	12.7	15.4	8.3	11.0	7.9	7.3	-	4.4	-	-	-	-	-
248	-	-	15.4	7.9	-	7.5	7.3	-	4.4	-	-	-	-	-
256	-	-	15.4	7.0	-	7.0	7.3	-	4.4	-	-	-	-	-
264	-	-	15.4	6.4	-	7.0	7.3	-	4.4	-	-	-	-	-
272	-	-	15.4	-	-	6.8	-	-	4.4	-	-	-	-	-
280	-	-	15.4	-	-	6.7	-	-	4.4	-	-	-	-	-

Max. capacities with minimum counterweight · Further counterweight configurations on request

- 132,300 lb
- 176,400 lb
- 220,500 lb
- 264,600 lb
- 308,600 lb
- 352,700 lb

WIHI-SSL 0° / 60°

AC 700-9

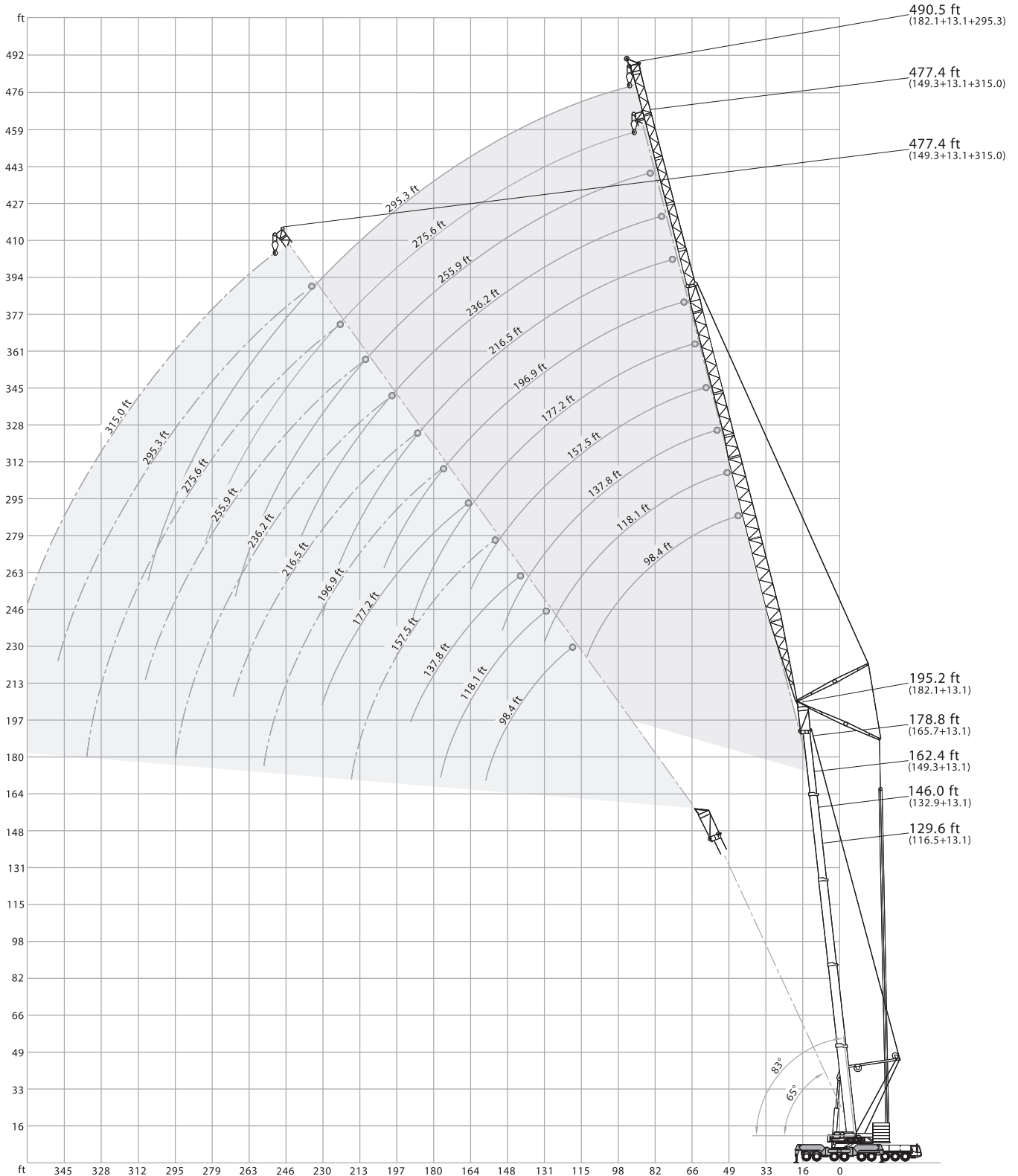

360°													85%					
116.5 ft + 13.1 ft																		
ft	98.4 ft			118.1 ft			137.8 ft			157.5 ft			177.2 ft			196.6 ft		
	83°*	73°	65°	83°*	73°	65°	83°*	73°	65°	83°*	73°	65°	83°*	73°	65°	83°*	73°	65°
	1,000 lb																	
56	202.8	-	-	-	-	-	-	-	-	-	-	-	-	-	-	-	-	-
64	196.2	-	-	174.2	-	-	-	-	-	-	-	-	-	-	-	-	-	-
72	182.2	-	-	170.9	-	-	146.6	-	-	-	-	-	-	-	-	-	-	-
80	169.8	-	-	163.0	-	-	146.2	-	-	125.9	-	-	107.6	-	-	-	-	-
88	157.3	-	-	152.9	-	-	142.6	-	-	122.6	-	-	104.9	-	-	88.4	-	-
96	146.6	134.4	-	143.3	116.2	-	136.5	-	-	119.2	-	-	102.2	-	-	86.8	-	-
104	134.9	127.6	-	134.4	112.8	-	129.8	-	-	116.1	-	-	100.5	-	-	85.0	-	-
112	-	120.5	-	125.1	109.3	-	123.1	98.5	-	112.2	-	-	98.0	-	-	83.7	-	-
120	-	111.7	103.4	112.9	105.0	-	116.4	98.0	-	108.5	78.3	-	95.3	-	-	82.4	-	-
128	-	69.4	96.2	-	100.1	94.1	109.1	96.8	-	104.7	78.3	-	93.1	66.1	-	80.5	-	-
136	-	-	89.8	-	94.0	88.0	97.0	93.5	-	100.1	78.3	-	91.0	66.1	-	78.6	59.5	-
144	-	-	84.2	-	87.8	82.3	80.1	88.0	80.3	94.0	77.4	-	87.3	66.1	-	77.2	59.5	-
152	-	-	-	-	-	77.4	-	82.6	75.2	82.1	76.1	73.5	84.2	66.0	-	75.7	59.5	-
160	-	-	-	-	-	72.9	-	77.7	70.8	69.9	72.8	69.0	77.1	65.3	-	73.0	59.5	-
168	-	-	-	-	-	-	-	-	66.9	-	69.6	65.1	67.1	64.0	63.6	70.3	59.3	-
176	-	-	-	-	-	-	-	-	63.2	-	66.4	61.4	58.0	61.8	60.0	67.6	58.7	59.1
184	-	-	-	-	-	-	-	-	33.7	-	37.8	58.1	-	59.5	56.8	60.8	57.0	56.1
192	-	-	-	-	-	-	-	-	-	-	-	55.0	-	57.3	53.7	53.2	55.4	53.0
200	-	-	-	-	-	-	-	-	-	-	-	52.2	-	55.2	51.0	45.2	53.5	50.2
208	-	-	-	-	-	-	-	-	-	-	-	-	-	48.4	-	51.8	47.6	-
216	-	-	-	-	-	-	-	-	-	-	-	-	-	45.8	-	50.0	45.1	-
224	-	-	-	-	-	-	-	-	-	-	-	-	-	-	-	26.3	43.2	-
232	-	-	-	-	-	-	-	-	-	-	-	-	-	-	-	-	41.1	-
240	-	-	-	-	-	-	-	-	-	-	-	-	-	-	-	-	39.1	-

ft	216.5 ft			236.2 ft			255.9 ft			275.6 ft			295.3 ft			315.0 ft		
	1,000 lb																	
96	69.9	-	-	60.6	-	-	-	-	-	-	-	-	-	-	-	-	-	-
104	68.5	-	-	59.4	-	-	49.5	-	-	-	-	-	-	-	-	-	-	-
112	67.2	-	-	58.1	-	-	48.4	-	-	39.0	-	-	31.0	-	-	-	-	-
120	66.1	-	-	57.0	-	-	47.4	-	-	37.9	-	-	30.3	-	-	24.6	-	-
128	65.6	-	-	55.9	-	-	46.3	-	-	37.0	-	-	29.6	-	-	24.0	-	-
136	64.6	-	-	54.9	-	-	45.1	-	-	36.1	-	-	29.0	-	-	23.3	-	-
144	63.7	46.3	-	54.0	-	-	44.3	-	-	35.1	-	-	28.3	-	-	22.7	-	-
152	62.7	46.3	-	53.5	40.8	-	43.6	-	-	34.3	-	-	27.5	-	-	22.2	-	-
160	61.9	46.3	-	52.7	40.8	-	43.0	35.3	-	33.5	-	-	26.9	-	-	21.4	-	-
168	60.9	46.3	-	51.9	40.8	-	42.3	35.3	-	32.7	28.7	-	26.1	-	-	20.9	-	-
176	59.7	46.3	-	51.0	40.8	-	41.7	35.3	-	32.1	28.7	-	25.5	-	-	20.4	-	-
184	58.6	46.1	46.3	50.1	40.8	-	41.0	35.3	-	31.3	28.7	-	24.8	22.9	-	19.7	-	-
192	56.6	45.9	46.3	49.2	40.8	-	40.2	35.3	-	30.5	28.7	-	24.1	22.9	-	19.1	17.8	-
200	50.9	45.2	46.3	48.1	40.6	40.8	39.4	35.3	-	29.8	28.7	-	23.3	22.7	-	18.5	17.6	-
208	45.0	44.7	45.4	45.9	40.3	40.8	38.6	35.3	35.3	29.2	28.7	-	22.6	22.6	-	18.0	17.5	-
216	38.8	44.1	43.4	43.0	39.7	40.8	37.8	35.1	35.3	28.5	28.7	-	22.1	22.5	-	17.5	17.2	-
224	-	43.6	41.2	38.0	39.2	39.4	36.8	34.8	35.3	27.8	28.6	28.4	21.8	22.3	-	16.9	16.9	-
232	-	42.9	39.1	32.8	38.6	37.4	35.3	34.5	35.1	27.2	28.3	27.9	21.5	22.2	23.0	16.4	16.7	-
240	-	41.8	37.3	27.3	38.1	35.6	32.3	34.1	34.6	26.8	27.9	27.5	21.1	22.1	22.6	16.0	16.4	-
248	-	-	35.5	-	37.5	33.7	28.5	33.7	33.3	26.4	27.4	27.1	20.8	21.8	22.2	15.6	16.2	16.9
256	-	-	-	-	16.5	31.9	-	33.3	31.5	26.0	26.9	26.7	20.5	21.4	21.8	15.2	16.1	16.5
264	-	-	-	-	-	30.5	-	32.9	30.0	23.8	26.5	26.4	20.2	21.1	21.4	14.8	15.7	16.3
272	-	-	-	-	-	29.0	-	31.7	28.6	21.0	26.0	26.1	19.9	20.8	21.1	14.5	15.3	16.0
280	-	-	-	-	-	-	-	29.1	27.3	17.1	25.5	25.7	19.5	20.4	20.8	14.2	15.1	15.7
288	-	-	-	-	-	-	-	-	25.9	-	25.1	25.1	17.4	20.1	20.5	13.9	14.7	15.5
296	-	-	-	-	-	-	-	-	-	-	11.4	24.4	-	19.8	20.3	13.6	14.3	15.2
304	-	-	-	-	-	-	-	-	-	-	-	23.3	-	19.4	20.0	13.4	14.0	14.8
312	-	-	-	-	-	-	-	-	-	-	-	22.2	-	19.1	19.7	11.9	13.8	14.4
320	-	-	-	-	-	-	-	-	-	-	-	-	-	18.8	19.5	9.1	13.5	14.2
328	-	-	-	-	-	-	-	-	-	-	-	-	-	-	19.1	-	13.1	13.8
336	-	-	-	-	-	-	-	-	-	-	-	-	-	-	-	7.2	-	13.4
344	-	-	-	-	-	-	-	-	-	-	-	-	-	-	-	-	-	13.1
352	-	-	-	-	-	-	-	-	-	-	-	-	-	-	-	-	-	12.9

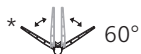
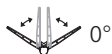

Max. capacities with minimum counterweight · Further counterweight configurations on request

176,400 lb 220,500 lb 264,600 lb 308,600 lb 352,700 lb

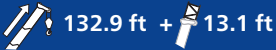
 360°																85%		
																		
ft	98.4 ft			118.1 ft			137.8 ft			157.5 ft			177.2 ft			196.6 ft		
	83°*	73°	65°	83°*	73°	65°	83°*	73°	65°	83°*	73°	65°	83°*	73°	65°	83°*	73°	65°
1,000 lb																		
64	157.0	-	-	-	-	-	-	-	-	-	-	-	-	-	-	-	-	-
72	143.6	-	-	142.3	-	-	-	-	-	-	-	-	-	-	-	-	-	-
80	133.9	-	-	131.7	-	-	128.4	-	-	117.8	-	-	-	-	-	-	-	-
88	124.7	-	-	121.8	-	-	119.2	-	-	111.7	-	-	100.1	-	-	84.0	-	-
96	116.0	116.5	-	113.8	-	-	111.2	-	-	106.3	-	-	96.7	-	-	82.0	-	-
104	107.0	109.4	-	105.7	93.9	-	104.4	-	-	101.0	-	-	94.0	-	-	80.6	-	-
112	-	102.1	-	98.8	92.3	-	97.7	78.5	-	94.5	-	-	90.2	-	-	79.3	-	-
120	-	95.8	-	91.0	90.4	-	91.3	78.2	-	89.1	64.4	-	86.1	-	-	77.6	-	-
128	-	89.5	92.3	-	87.4	-	85.9	78.0	-	83.7	64.4	-	81.5	55.6	-	74.9	-	-
136	-	82.4	87.5	-	82.1	84.5	79.8	77.9	-	79.2	64.4	-	77.0	55.6	-	72.3	-	-
144	-	-	82.3	-	76.7	80.2	74.1	74.7	-	74.1	64.4	-	72.9	55.6	-	69.6	48.3	-
152	-	-	46.3	-	52.4	75.3	-	70.8	72.3	69.8	64.0	-	68.9	55.6	-	66.9	48.3	-
160	-	-	-	-	-	71.0	-	66.5	68.7	64.9	61.6	63.3	65.1	55.6	-	64.1	48.3	-
168	-	-	-	-	-	38.8	-	43.7	65.1	-	59.2	61.5	61.6	54.5	55.2	61.0	48.3	-
176	-	-	-	-	-	-	-	-	61.4	-	56.6	59.4	57.7	52.5	54.0	57.8	48.3	-
184	-	-	-	-	-	-	-	-	58.1	-	53.9	56.3	-	50.4	52.4	54.6	47.1	47.8
192	-	-	-	-	-	-	-	-	-	-	-	53.2	-	48.5	51.0	50.9	45.7	47.0
200	-	-	-	-	-	-	-	-	-	-	-	50.5	-	46.3	49.0	45.8	44.1	46.3
208	-	-	-	-	-	-	-	-	-	-	-	23.7	-	28.4	46.7	-	42.7	45.3
216	-	-	-	-	-	-	-	-	-	-	-	-	-	-	44.3	-	41.1	43.6
224	-	-	-	-	-	-	-	-	-	-	-	-	-	-	42.3	-	39.5	41.6
232	-	-	-	-	-	-	-	-	-	-	-	-	-	-	-	-	-	39.6
240	-	-	-	-	-	-	-	-	-	-	-	-	-	-	-	-	-	37.7
248	-	-	-	-	-	-	-	-	-	-	-	-	-	-	-	-	-	15.3

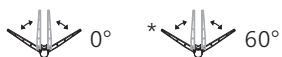

Max. capacities with minimum counterweight · Further counterweight configurations on request

-  176,400 lb
-  220,500 lb
-  264,600 lb
-  308,600 lb
-  352,700 lb

WIHI-SSL 0° / 60°



AC 700-9

360°																85%			
132.9 ft + 13.1 ft																			
ft	216.5 ft			236.2 ft			255.9 ft			275.6 ft			295.3 ft			315.0 ft			
	83°*	73°	65°	83°*	73°	65°	83°*	73°	65°	83°*	73°	65°	83°*	73°	65°	83°*	73°	65°	
1,000 lb																			
96	67.6	-	-	-	-	-	-	-	-	-	-	-	-	-	-	-	-	-	-
104	66.3	-	-	56.1	-	-	46.4	-	-	-	-	-	-	-	-	-	-	-	-
112	66.1	-	-	55.3	-	-	45.8	-	-	37.0	-	-	-	-	-	-	-	-	-
120	65.2	-	-	54.7	-	-	45.3	-	-	36.3	-	-	29.2	-	-	-	-	-	-
128	64.1	-	-	53.9	-	-	44.5	-	-	35.7	-	-	28.7	-	-	22.5	-	-	-
136	63.1	-	-	53.3	-	-	44.0	-	-	35.2	-	-	28.1	-	-	22.1	-	-	-
144	62.2	-	-	52.5	-	-	43.5	-	-	34.4	-	-	27.6	-	-	21.8	-	-	-
152	61.1	37.5	-	51.9	-	-	42.9	-	-	33.9	-	-	27.0	-	-	21.3	-	-	-
160	60.2	37.5	-	51.2	31.5	-	42.2	-	-	33.3	-	-	26.5	-	-	21.1	-	-	-
168	58.6	37.5	-	50.6	31.5	-	41.6	27.3	-	32.5	-	-	25.9	-	-	20.7	-	-	-
176	56.3	37.5	-	49.9	31.5	-	41.1	27.3	-	31.8	21.6	-	25.2	-	-	20.1	-	-	-
184	53.6	37.5	-	48.6	31.5	-	40.5	27.3	-	31.2	21.6	-	24.7	17.4	-	19.6	-	-	-
192	50.8	37.3	37.5	47.1	31.5	-	39.9	27.3	-	30.5	21.6	-	24.1	17.2	-	19.1	11.9	-	-
200	48.1	36.6	37.5	45.4	31.5	-	39.0	27.3	-	29.8	21.6	-	23.4	17.2	-	18.5	11.8	-	-
208	44.4	36.1	37.5	43.8	31.2	31.5	38.1	27.3	-	29.2	21.6	-	22.8	17.0	-	18.0	11.5	-	-
216	40.0	35.5	37.5	42.2	30.9	31.5	37.3	27.3	27.3	28.5	21.6	-	22.1	17.0	-	17.5	11.3	-	-
224	-	34.8	37.0	38.3	30.4	31.5	36.5	27.1	27.3	27.8	21.6	-	21.5	16.8	-	16.9	11.0	-	-
232	-	34.2	36.2	33.9	30.1	31.4	35.2	26.8	27.3	27.1	21.5	21.3	21.0	16.7	-	16.4	10.9	-	-
240	-	33.5	35.0	28.5	29.7	31.2	32.8	26.5	27.3	26.5	21.3	21.0	20.5	16.5	16.4	16.0	10.7	-	-
248	-	18.5	33.7	-	29.3	30.6	29.2	26.3	27.2	25.9	21.0	20.9	19.9	16.4	16.2	15.6	10.4	-	-
256	-	-	32.4	-	28.9	29.8	-	26.0	27.1	25.3	20.7	20.7	19.4	16.3	16.1	15.2	10.4	10.8	-
264	-	-	30.9	-	28.6	28.8	-	25.7	26.4	23.9	20.6	20.5	19.0	16.0	16.0	14.8	10.1	10.7	-
272	-	-	-	-	-	27.7	-	25.5	25.8	21.5	20.4	20.2	18.6	15.8	15.8	14.4	9.9	10.5	-
280	-	-	-	-	-	26.4	-	25.2	25.3	17.8	20.1	20.1	18.2	15.7	15.7	14.0	9.7	10.4	-
288	-	-	-	-	-	6.7	-	11.8	24.4	-	19.9	20.0	16.8	15.6	15.6	13.7	9.6	10.2	-
296	-	-	-	-	-	-	-	-	23.5	-	19.6	19.8	-	15.4	15.4	13.4	9.5	9.9	-
304	-	-	-	-	-	-	-	-	22.3	-	19.4	19.6	-	15.3	15.3	13.2	9.3	9.8	-
312	-	-	-	-	-	-	-	-	-	-	19.6	19.6	-	15.2	15.2	11.9	9.2	9.6	-
320	-	-	-	-	-	-	-	-	-	-	19.4	19.4	-	15.0	15.0	9.3	8.9	9.5	-
328	-	-	-	-	-	-	-	-	-	-	-	-	-	-	14.9	-	8.7	9.3	-
336	-	-	-	-	-	-	-	-	-	-	-	-	-	-	14.7	-	8.6	9.0	-
344	-	-	-	-	-	-	-	-	-	-	-	-	-	-	14.6	-	8.4	8.8	-
352	-	-	-	-	-	-	-	-	-	-	-	-	-	-	-	-	-	8.7	-
360	-	-	-	-	-	-	-	-	-	-	-	-	-	-	-	-	-	8.4	-



Max. capacities with minimum counterweight · Further counterweight configurations on request

- 176,400 lb
- 220,500 lb
- 264,600 lb
- 308,600 lb
- 352,700 lb

360°															85%			
 149.3 ft +  13.1 ft																		
ft	98.4 ft			118.1 ft			137.8 ft			157.5 ft			177.2 ft			196.6 ft		
	83°*	73°	65°	83°*	73°	65°	83°*	73°	65°	83°*	73°	65°	83°*	73°	65°	83°*	73°	65°
1,000 lb																		
64	146.6	-	-	-	-	-	-	-	-	-	-	-	-	-	-	-	-	-
72	139.1	-	-	132.5	-	-	-	-	-	-	-	-	-	-	-	-	-	-
80	129.5	-	-	123.3	-	-	117.8	-	-	-	-	-	-	-	-	-	-	-
88	120.7	-	-	115.7	-	-	110.2	-	-	102.9	-	-	92.3	-	-	-	-	-
96	112.7	-	-	109.0	-	-	104.1	-	-	97.5	-	-	88.3	-	-	75.4	-	-
104	104.6	96.0	-	102.1	-	-	98.8	-	-	92.2	-	-	85.2	-	-	74.2	-	-
112	-	91.9	-	95.5	78.4	-	93.4	-	-	88.0	-	-	81.4	-	-	72.7	-	-
120	-	87.1	-	88.8	77.1	-	88.0	65.9	-	83.9	-	-	78.4	-	-	71.3	-	-
128	-	82.0	-	82.1	75.3	-	82.6	65.5	-	79.9	57.3	-	74.9	-	-	69.4	-	-
136	-	76.2	74.6	-	72.7	-	78.1	65.1	-	75.9	57.3	-	72.3	50.7	-	67.5	-	-
144	-	-	71.1	-	69.0	-	72.0	63.8	-	71.8	57.3	-	68.5	50.7	-	65.8	39.9	-
152	-	-	67.4	-	64.7	66.8	-	62.0	-	67.8	57.2	-	65.7	50.7	-	63.6	39.9	-
160	-	-	41.0	-	-	63.6	-	58.9	62.0	63.5	56.0	-	62.7	50.7	-	61.2	39.9	-
168	-	-	-	-	-	60.2	-	55.9	59.2	-	54.0	56.4	59.4	50.3	-	58.5	39.9	-
176	-	-	-	-	-	56.7	-	52.9	56.4	-	51.1	53.5	56.0	49.3	-	55.5	39.9	-
184	-	-	-	-	-	-	-	-	53.5	-	48.2	50.6	49.4	47.3	48.9	52.7	39.5	-
192	-	-	-	-	-	-	-	-	27.2	-	-	47.8	-	45.2	47.0	49.8	39.0	39.8
200	-	-	-	-	-	-	-	-	25.6	-	-	45.3	-	43.0	45.1	46.7	37.9	39.6
208	-	-	-	-	-	-	-	-	-	-	-	42.9	-	40.7	43.1	-	37.0	39.2
216	-	-	-	-	-	-	-	-	-	-	-	40.5	-	38.5	40.9	-	36.0	38.8
224	-	-	-	-	-	-	-	-	-	-	-	-	-	-	38.8	-	34.9	37.8
232	-	-	-	-	-	-	-	-	-	-	-	-	-	-	15.8	-	-	36.3
240	-	-	-	-	-	-	-	-	-	-	-	-	-	-	-	-	-	34.7
248	-	-	-	-	-	-	-	-	-	-	-	-	-	-	-	-	-	33.2



Max. capacities with minimum counterweight · Further counterweight configurations on request

-  176,400 lb
-  220,500 lb
-  264,600 lb
-  308,600 lb
-  352,700 lb

360°																85%			
149.3 ft + 13.1 ft																			
216.5 ft																			
236.2 ft																			
255.9 ft																			
275.6 ft																			
295.3 ft																			
315.0 ft																			
ft	83°*	73°	65°	83°*	73°	65°	83°*	73°	65°	83°*	73°	65°	83°*	73°	65°	83°*	73°	65°	
1,000 lb																			
104	62.7	-	-	53.0	-	-	-	-	-	-	-	-	-	-	-	-	-	-	-
112	62.4	-	-	52.7	-	-	43.2	-	-	-	-	-	-	-	-	-	-	-	-
120	61.8	-	-	52.2	-	-	42.9	-	-	34.9	-	-	27.4	-	-	-	-	-	-
128	61.2	-	-	51.9	-	-	42.4	-	-	34.4	-	-	27.0	-	-	21.3	-	-	-
136	60.5	-	-	51.5	-	-	42.2	-	-	34.0	-	-	26.7	-	-	21.0	-	-	-
144	59.4	-	-	51.2	-	-	41.9	-	-	33.5	-	-	26.5	-	-	20.7	-	-	-
152	58.2	32.4	-	50.6	-	-	41.4	-	-	33.0	-	-	26.2	-	-	20.5	-	-	-
160	57.0	32.4	-	50.1	-	-	41.1	-	-	32.5	-	-	25.9	-	-	20.4	-	-	-
168	55.6	32.4	-	49.6	25.4	-	40.6	20.5	-	31.9	-	-	25.5	-	-	20.1	-	-	-
176	54.0	32.4	-	49.0	25.4	-	40.2	20.5	-	31.4	-	-	25.0	-	-	19.9	-	-	-
184	51.6	32.4	-	48.0	25.4	-	39.7	20.5	-	30.7	14.3	-	24.5	-	-	19.5	-	-	-
192	49.1	32.4	-	46.7	25.4	-	39.1	20.5	-	30.1	14.3	-	23.9	9.9	-	19.1	-	-	-
200	46.5	32.2	-	44.6	25.4	-	38.6	20.5	-	29.6	14.3	-	23.2	9.9	-	18.5	5.5	-	-
208	43.8	32.0	32.4	42.4	25.4	-	37.8	20.5	-	28.9	14.3	-	22.6	9.9	-	18.0	5.5	-	-
216	41.0	31.8	32.4	40.3	25.4	25.4	36.9	20.5	-	28.3	14.3	-	22.1	9.9	-	17.5	5.5	-	-
224	34.3	31.5	32.4	38.0	25.4	25.4	35.9	20.5	19.8	27.7	14.3	-	21.5	9.9	-	16.9	5.5	-	-
232	-	31.2	32.2	34.8	25.4	25.4	34.8	20.5	19.8	27.1	14.3	-	21.0	9.9	-	16.4	5.5	-	-
240	-	31.0	31.5	29.4	25.4	25.4	33.2	20.5	19.8	26.5	14.3	14.3	20.5	9.9	-	16.0	5.5	-	-
248	-	30.6	30.6	-	25.4	25.2	29.8	20.5	19.8	25.9	14.3	14.3	20.0	9.9	9.9	15.6	5.5	-	-
256	-	-	29.5	-	25.4	24.9	25.5	20.5	19.8	25.3	14.3	14.3	19.6	9.9	9.9	15.2	5.5	5.5	-
264	-	-	28.5	-	25.4	24.6	20.7	20.5	19.8	24.1	14.3	14.3	19.1	9.9	9.9	14.8	5.5	5.5	-
272	-	-	8.6	-	-	24.3	-	20.5	19.8	22.0	14.3	14.3	18.6	9.9	9.9	14.4	5.5	5.5	-
280	-	-	-	-	-	23.9	-	20.5	19.8	18.2	14.3	14.3	18.2	9.9	9.9	14.0	5.5	5.5	-
288	-	-	-	-	-	23.3	-	20.5	19.8	-	14.3	14.3	17.0	9.9	9.9	13.7	5.5	5.5	-
296	-	-	-	-	-	-	-	-	19.8	-	14.3	14.3	15.3	9.9	9.9	13.4	5.5	5.5	-
304	-	-	-	-	-	-	-	-	19.8	-	14.3	14.3	11.8	9.9	9.9	13.2	5.5	5.5	-
312	-	-	-	-	-	-	-	-	-	-	14.3	14.3	-	9.9	9.9	11.9	5.5	5.5	-
320	-	-	-	-	-	-	-	-	-	-	14.3	14.3	-	9.9	9.9	9.5	5.5	5.5	-
328	-	-	-	-	-	-	-	-	-	-	14.3	14.3	-	9.9	9.9	-	5.5	5.5	-
336	-	-	-	-	-	-	-	-	-	-	-	-	-	9.9	9.9	-	5.5	5.5	-
344	-	-	-	-	-	-	-	-	-	-	-	-	-	9.9	9.9	-	5.5	5.5	-
352	-	-	-	-	-	-	-	-	-	-	-	-	-	-	-	-	-	5.5	-
360	-	-	-	-	-	-	-	-	-	-	-	-	-	-	-	-	-	5.5	-
368	-	-	-	-	-	-	-	-	-	-	-	-	-	-	-	-	-	5.5	-

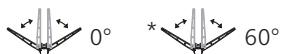

Max. capacities with minimum counterweight · Further counterweight configurations on request

- 176,400 lb
- 220,500 lb
- 264,600 lb
- 308,600 lb
- 352,700 lb

360°															85%			
165.7 ft + 13.1 ft																		
ft	98.4 ft			118.1 ft			137.8 ft			157.5 ft			177.2 ft			196.6 ft		
	83°*	73°	65°	83°*	73°	65°	83°*	73°	65°	83°*	73°	65°	83°*	73°	65°	83°*	73°	65°
1,000 lb																		
72	111.5	-	-	-	-	-	-	-	-	-	-	-	-	-	-	-	-	-
80	103.7	-	-	99.0	-	-	95.9	-	-	-	-	-	-	-	-	-	-	-
88	96.9	-	-	91.9	-	-	89.2	-	-	83.1	-	-	-	-	-	-	-	-
96	90.9	-	-	86.8	-	-	83.2	-	-	78.0	-	-	73.6	-	-	65.3	-	-
104	85.5	-	-	82.2	-	-	78.6	-	-	73.4	-	-	69.8	-	-	63.3	-	-
112	-	67.9	-	78.0	58.5	-	74.7	-	-	69.2	-	-	66.0	-	-	61.2	-	-
120	-	63.9	-	72.9	56.7	-	70.7	-	-	65.6	-	-	62.9	-	-	59.0	-	-
128	-	60.1	-	68.9	54.8	-	67.2	48.1	-	63.0	-	-	59.7	-	-	56.8	-	-
136	-	56.4	-	-	52.7	-	64.1	47.4	-	60.0	43.7	-	57.0	-	-	54.5	-	-
144	-	52.8	53.0	-	50.2	-	60.6	46.6	-	57.2	42.6	-	54.4	37.3	-	52.1	-	-
152	-	-	50.4	-	47.2	47.1	-	45.5	-	54.5	41.7	-	51.7	36.7	-	49.9	29.1	-
160	-	-	47.9	-	44.3	44.7	-	43.0	-	51.8	40.7	-	49.6	36.2	-	47.6	29.1	-
168	-	-	-	-	-	42.4	-	40.7	40.1	-	39.1	-	47.5	35.7	-	45.7	29.1	-
176	-	-	-	-	-	40.2	-	38.3	38.2	-	37.1	35.9	45.5	35.1	-	43.9	29.1	-
184	-	-	-	-	-	30.4	-	-	36.3	-	35.2	34.1	43.0	33.7	31.9	42.0	29.1	-
192	-	-	-	-	-	-	-	-	34.4	-	33.1	32.5	-	32.0	30.6	40.2	28.9	-
200	-	-	-	-	-	-	-	-	32.7	-	31.1	30.9	-	30.2	29.1	38.3	27.8	27.7
208	-	-	-	-	-	-	-	-	-	-	-	29.4	-	28.6	27.7	-	26.7	26.5
216	-	-	-	-	-	-	-	-	-	-	-	27.9	-	27.0	26.3	-	25.4	25.2
224	-	-	-	-	-	-	-	-	-	-	-	17.5	-	-	25.2	-	24.4	24.1
232	-	-	-	-	-	-	-	-	-	-	-	-	-	-	23.9	-	23.3	22.8
240	-	-	-	-	-	-	-	-	-	-	-	-	-	-	22.7	-	22.2	21.8
248	-	-	-	-	-	-	-	-	-	-	-	-	-	-	-	-	-	20.7
256	-	-	-	-	-	-	-	-	-	-	-	-	-	-	-	-	-	11.2
264	-	-	-	-	-	-	-	-	-	-	-	-	-	-	-	-	-	10.5



Max. capacities with minimum counterweight · Further counterweight configurations on request

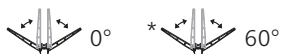

- 176,400 lb
- 220,500 lb
- 264,600 lb
- 308,600 lb
- 352,700 lb

360°																		85%
165.7 ft + 13.1 ft																		
ft	216.5 ft			236.2 ft			255.9 ft			275.6 ft			295.3 ft			315.0 ft		
	83°*	73°	65°	83°*	73°	65°	83°*	73°	65°	83°*	73°	65°	83°*	73°	65°	83°*	73°	65°
1,000 lb																		
104	56.0	-	-	-	-	-	-	-	-	-	-	-	-	-	-	-	-	-
112	54.3	-	-	44.3	-	-	37.2	-	-	-	-	-	-	-	-	-	-	-
120	52.5	-	-	43.2	-	-	36.7	-	-	30.4	-	-	-	-	-	-	-	-
128	50.8	-	-	42.3	-	-	36.2	-	-	30.0	-	-	23.5	-	-	-	-	-
136	49.1	-	-	41.2	-	-	35.6	-	-	29.6	-	-	23.2	-	-	-	-	-
144	47.3	-	-	40.4	-	-	35.1	-	-	29.3	-	-	23.1	-	-	-	-	-
152	45.4	-	-	39.3	-	-	34.3	-	-	28.8	-	-	22.9	-	-	-	-	-
160	43.5	21.4	-	38.2	-	-	33.8	-	-	28.6	-	-	22.8	-	-	-	-	-
168	41.6	21.4	-	37.2	15.7	-	33.2	-	-	28.2	-	-	22.6	-	-	-	-	-
176	39.7	21.4	-	36.1	15.7	-	32.5	12.6	-	27.6	-	-	22.3	-	-	-	-	-
184	38.3	21.4	-	35.0	15.7	-	31.8	12.6	-	27.2	9.5	-	22.0	-	-	-	-	-
192	37.0	21.4	-	33.9	15.7	-	31.2	12.6	-	26.8	9.5	-	21.8	-	-	-	-	-
200	35.6	21.4	-	32.9	15.7	-	30.5	12.6	-	26.2	9.5	-	21.5	-	-	-	-	-
208	34.1	21.1	21.2	31.8	15.7	-	29.7	12.6	-	25.8	9.5	-	21.2	-	-	-	-	-
216	32.5	20.5	20.8	30.7	15.7	-	28.9	12.6	-	25.4	9.5	-	20.8	-	-	-	-	-
224	30.8	20.0	20.5	29.6	15.4	15.7	28.0	12.6	-	24.7	9.5	-	20.5	-	-	-	-	-
232	-	19.5	20.1	28.4	15.4	15.7	27.1	12.6	12.6	24.1	9.5	-	20.2	-	-	-	-	-
240	-	18.9	19.6	27.0	15.1	15.7	26.3	12.6	12.6	23.6	9.5	-	19.8	-	-	-	-	-
248	-	18.4	18.8	-	14.9	15.7	25.2	12.5	12.6	23.0	9.5	9.5	19.4	-	-	-	-	-
256	-	-	17.8	-	14.8	15.6	24.0	12.3	12.6	22.5	9.5	9.5	19.2	-	-	-	-	-
264	-	-	16.9	-	14.5	15.0	20.6	12.2	12.6	21.8	9.5	9.5	18.8	-	-	-	-	-
272	-	-	16.0	-	14.3	14.3	-	12.1	12.4	20.5	9.5	9.5	18.4	-	-	-	-	-
280	-	-	15.0	-	14.1	13.4	-	11.9	12.0	18.3	9.5	9.5	18.0	-	-	-	-	-
288	-	-	-	-	-	12.7	-	11.8	11.5	-	9.5	9.3	17.0	-	-	-	-	-
296	-	-	-	-	-	-	-	-	11.0	-	9.5	9.0	15.6	-	-	-	-	-
304	-	-	-	-	-	-	-	-	10.4	-	9.5	8.7	12.2	-	-	-	-	-
312	-	-	-	-	-	-	-	-	9.9	-	9.5	8.5	-	-	-	-	-	-
320	-	-	-	-	-	-	-	-	9.4	-	-	8.3	-	-	-	-	-	-
328	-	-	-	-	-	-	-	-	-	-	-	7.9	-	-	-	-	-	-



Max. capacities with minimum counterweight · Further counterweight configurations on request

- 176,400 lb
- 220,500 lb
- 264,600 lb
- 308,600 lb
- 352,700 lb

 360°																85%		
 182.1 ft +  13.1 ft																		
ft	98.4 ft			118.1 ft			137.8 ft			157.5 ft			177.2 ft			196.6 ft		
	83°*	73°	65°	83°*	73°	65°	83°*	73°	65°	83°*	73°	65°	83°*	73°	65°	83°*	73°	65°
1,000 lb																		
72	87.3	-	-	-	-	-	-	-	-	-	-	-	-	-	-	-	-	-
80	80.7	-	-	76.3	-	-	-	-	-	-	-	-	-	-	-	-	-	-
88	75.3	-	-	70.9	-	-	68.5	-	-	-	-	-	-	-	-	-	-	-
96	71.1	-	-	66.9	-	-	64.1	-	-	60.0	-	-	53.9	-	-	-	-	-
104	67.6	-	-	63.7	-	-	60.6	-	-	56.2	-	-	51.3	-	-	47.0	-	-
112	-	53.7	-	60.5	-	-	57.2	-	-	52.6	-	-	48.4	-	-	44.9	-	-
120	-	52.9	-	58.6	41.9	-	54.4	-	-	50.2	-	-	45.9	-	-	42.7	-	-
128	-	51.7	-	57.0	41.9	-	52.0	34.6	-	47.9	-	-	43.5	-	-	40.7	-	-
136	-	49.6	-	-	41.9	-	50.4	34.6	-	45.5	-	-	41.6	-	-	38.9	-	-
144	-	47.1	-	-	41.3	-	49.0	34.6	-	43.9	30.4	-	39.8	-	-	37.3	-	-
152	-	-	44.7	-	40.3	-	-	34.5	-	42.8	30.2	-	38.0	25.4	-	35.7	-	-
160	-	-	42.4	-	38.9	-	-	34.0	-	41.5	29.8	-	36.9	25.4	-	34.2	19.4	-
168	-	-	34.7	-	-	37.6	-	33.3	-	-	29.3	-	35.9	25.4	-	33.0	19.4	-
176	-	-	32.5	-	-	35.8	-	32.5	32.7	-	28.7	-	35.0	25.4	-	31.9	19.4	-
184	-	-	-	-	-	34.1	-	31.7	31.7	-	28.0	28.4	34.1	25.1	-	30.8	19.4	-
192	-	-	-	-	-	-	-	-	30.6	-	27.4	27.5	-	24.8	-	29.8	19.4	-
200	-	-	-	-	-	-	-	29.2	-	26.6	26.6	-	24.3	24.5	28.8	19.4	-	-
208	-	-	-	-	-	-	-	21.1	-	-	25.6	-	23.7	23.6	-	19.4	19.4	-
216	-	-	-	-	-	-	-	19.7	-	-	24.5	-	23.2	22.6	-	19.4	19.4	-
224	-	-	-	-	-	-	-	-	-	-	23.2	-	21.5	21.7	-	19.4	19.4	-
232	-	-	-	-	-	-	-	-	-	-	-	-	-	20.7	-	19.4	19.3	-
240	-	-	-	-	-	-	-	-	-	-	-	-	-	19.7	-	19.4	18.9	-
248	-	-	-	-	-	-	-	-	-	-	-	-	-	11.0	-	-	18.2	-
256	-	-	-	-	-	-	-	-	-	-	-	-	-	-	-	-	17.4	-
264	-	-	-	-	-	-	-	-	-	-	-	-	-	-	-	-	16.6	-

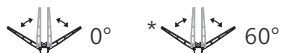

Max. capacities with minimum counterweight · Further counterweight configurations on request

-  176,400 lb
-  220,500 lb
-  264,600 lb
-  308,600 lb
-  352,700 lb

360°																85%	
182.1 ft + 13.1 ft																	
216.5 ft																	
236.2 ft																	
255.9 ft																	
275.6 ft																	
295.3 ft																	
315.0 ft																	
ft	83°*	73°	65°	83°*	73°	65°	83°*	73°	65°	83°*	73°	65°	83°*	73°	65°	1,000 lb	
112	39.8	-	-	35.0	-	-	-	-	-	-	-	-	-	-	-	-	-
120	38.0	-	-	33.6	-	-	29.9	-	-	-	-	-	-	-	-	-	-
128	36.3	-	-	32.1	-	-	28.9	-	-	23.8	-	-	17.9	-	-	-	-
136	34.5	-	-	30.7	-	-	27.6	-	-	23.1	-	-	17.9	-	-	-	-
144	33.1	-	-	29.2	-	-	26.5	-	-	22.5	-	-	17.6	-	-	-	-
152	31.8	-	-	27.9	-	-	25.4	-	-	22.0	-	-	17.4	-	-	-	-
160	30.7	-	-	27.0	-	-	24.4	-	-	21.4	-	-	17.3	-	-	-	-
168	29.5	14.3	-	26.1	-	-	23.6	-	-	20.7	-	-	17.1	-	-	-	-
176	28.4	14.3	-	25.3	11.0	-	22.8	-	-	20.3	-	-	17.0	-	-	-	-
184	27.5	14.3	-	24.3	11.0	-	22.0	7.3	-	19.8	-	-	16.7	-	-	-	-
192	26.7	14.3	-	23.4	11.0	-	21.2	7.3	-	19.3	-	-	16.5	-	-	-	-
200	25.9	14.3	-	22.8	11.0	-	20.6	7.3	-	18.7	-	-	16.2	-	-	-	-
208	25.2	14.3	-	22.1	11.0	-	20.0	7.3	-	18.3	-	-	15.9	-	-	-	-
216	24.5	14.3	-	21.4	11.0	-	19.4	7.3	-	17.9	-	-	15.5	-	-	-	-
224	23.6	14.3	14.1	20.8	11.0	-	18.8	7.3	-	17.4	-	-	15.2	-	-	-	-
232	-	14.3	13.8	20.1	11.0	8.8	18.1	7.3	-	16.8	-	-	14.9	-	-	-	-
240	-	14.3	13.5	19.4	11.0	8.8	17.6	7.3	7.3	16.3	-	-	14.5	-	-	-	-
248	-	14.3	13.3	-	11.0	8.8	17.1	7.3	7.3	15.7	-	-	14.1	-	-	-	-
256	-	14.1	13.0	-	11.0	8.8	16.5	7.3	7.3	15.2	-	-	13.7	-	-	-	-
264	-	13.3	12.6	-	11.0	8.8	16.0	7.3	7.3	14.8	-	-	13.1	-	-	-	-
272	-	-	12.2	-	11.0	8.8	-	7.3	7.3	14.4	-	-	12.6	-	-	-	-
280	-	-	11.8	-	11.0	8.8	-	7.3	7.3	13.8	-	-	12.2	-	-	-	-
288	-	-	-	-	-	8.8	-	7.3	7.2	-	-	-	11.8	-	-	-	-
296	-	-	-	-	-	8.8	-	7.3	7.0	-	-	-	11.4	-	-	-	-
304	-	-	-	-	-	8.8	-	7.3	6.9	-	-	-	11.0	-	-	-	-
312	-	-	-	-	-	-	-	-	6.8	-	-	-	-	-	-	-	-
320	-	-	-	-	-	-	-	-	6.6	-	-	-	-	-	-	-	-



Max. capacities with minimum counterweight · Further counterweight configurations on request

- 176,400 lb
- 220,500 lb
- 264,600 lb
- 308,600 lb
- 352,700 lb

Basic machine

Equipment carrier

Engine 460-4	Mercedes-Benz OM473LA; Output 460 kW / 1700 1/min (625 HP), torque 2900 Nm / 1300 1/min; Certifications in accordance with EU Stage IV / Tier 4F. Fuel tank 217 gallons Diesel (no RME / biodiesel); 25 gallons tank for AdBlue.
Transmission TC	ZF TC-Tronic; Automated gearbox with integrated torque converter and hydraulic retarder, 12 forward speeds and 2 reverse; Selectable longitudinal lock included in transfer case.
Axles 18 x 8 x 16	18 x 8 x 16; 9 axles, axles 3, 4, 8, 9 driven equipped with selectable transverse lock, axles 1-5 and 7-9 steered, axle 6 liftable.
Suspension	Hydropneumatic suspension with axle load compensation; Hydraulically lockable; Manual or automatic levelling alternatively.
Steering	Dual-circuit semiblock mechanical steering with hydraulic booster.
Brakes	In conformity with EC-directives. Sustained action brake: constant decompression valve, exhaust brake, hydraulic retarder integrated into gearbox.
Tire size 385/95 R25 (14.00R25)	Tires size 385/95R25 (14.00R25); Steel rims 9,5-25/1,7"; TechKing ETCRANE 170F or similar.
Cab 2880	Type 9.45 ft; Adjustable driver seat with seat heating, armrests and pneumatic suspension; Steering wheel height and tilt adjustable; Co-driver's seat; Power door windows; Tinted glass; Radio-preparation.
Heating engine-dependent	Engine-dependent warm water heating with 12 kW heating power.
Aircondition	Aircondition for carrier cab with 7 kW cooling power.
Drive lights	With low beam, upper beam.
Outriggers	X-4-Point design; 4 outriggers telescopic; Vertical and horizontal movement fully hydraulic; Manual or automatic levelling alternatively; 2 outrigger bases.
Outrigger pads	4 outrigger pads with transport position at outrigger beam.
Outrigger quick connection	Hydraulic bolt extractors and hydraulic and electric quick couplings for fast (dis-) assembly.
Outrigger load indicator	Displayed in LMI crane cab.
Outrigger basis monitoring	Individual monitoring of horizontal stroke; Deviation warning in crane cab.
Cruise control	Automatic speed control including automatic brake control.
Central lubrication	Central auto lube for all lubrication points at carrier.
Electronic immobiliser system	Prevents uncontrolled carrier mobilisation; Incl. 2 electronic keys and 4 ignition keys.
Contour safety marking	Continuous reflective strips on the sides of the chassis and on the rear.

Equipment superstructure

Engine 210-4	Mercedes-Benz OM936LA; Output 210 kW / 2200 1/min (286 HP), torque 1150 Nm / 1200 1/min; Certifications in accordance with EU Stage IV / Tier 4F. Fuel tank 79 gallons Diesel (no RME / biodiesel); 11 gallons tank for AdBlue.
Telescopic boom HA60	50.9 ft - 196.9 ft; Single cylinder telescoping system, automatic telescoping; Attachments for all equipment and extensions; 9 sheaves integrated in boom head for max. capacity of 495,000 lb.
Boom luffing	Two differential cylinders with pilot-controlled lowering brake valves.
Rotary drive	Axial piston motor with planetary gearing, foot-operated brake, and spring-applied holding brake.
H1	Axial piston variable displacement motor, hoist drum with integrated planetary gear reducer, and brake.
Counterweight system 44,100 lb	44,100 lb (base frame); Self rigging with semiautomatic rigging system, rigging storage on carrier front; Expandable to max. 352,700 lb; Incl. tightening device.
Control system	Enabling 4 simultaneous working movements; Electric pilot controls via 2 two-axis joysticks; Different control modes selectable for hydraulic circuits.
Operator aids	IC-1, with integrated electronic load moment indicator in accordance with EN13000; Color display; Displaying of current operating conditions, load charts, fault indicator; Signal lights indicating LMI-load; Crane data logger.
Working range limiter	Displaying and programmability of the work range limits by IC-1.
Cab 088	Type 2.87 ft; Tilt infinitely variable 20°; Seat heating; Sliding window in door and rear; Fold-out front window; Extendable side pedestal, foldable front pedestal; Handrails; Tinted safety glass; Pull-down sun visor and light curtains; Radio-preparation.
Heating engine independent	Engine independent Diesel heating system with 5 kW heating power; With timer and remote start.
Aircondition	Aircondition in crane cab with 7 kW cooling power.
Central lubrication	Central auto lube for all lubrication points at crane.
Anemometer	Removable, to be used with all extensions.

Additional equipment

Carrier

Engine 480-3	Mercedes-Benz OM502LA; Output 480 kW / 1800 1/min (653 HP), torque 2800 Nm / 1200 1/min, certifications in accordance with EU Stage IIIA / Tier 3. Fuel tank 174 gallons Diesel (no RME / biodiesel).
Self-assembly outriggers	2 x assembly outrigger; Road able in driving conditions with 26,500 lb axle load; Enabling self-rigging of the 4 main outriggers without assist crane.
32.8 ft x 32.8 ft outrigger base	Additional outrigger base of 32.8 ft x 32.8 ft for increased versatility. Crane can work on same outrigger base like 600 USt all terrain cranes.

Superstructure

Engine 205-3	Mercedes-Benz OM906LA; Output 205 kW / 2200 1/min (279 HP), torque 1100 Nm / 1200 1/min, certifications in accordance with EU Stage IIIA / Tier 3. Fuel tank 79 gallons Diesel (no RME / biodiesel).
Heavy lift attachment SSL	4 additional sheaves; For total 13 sheaves on boom head. Max. capacity of 688,000 lb. Sideways Superlift; Capacity increasing boom guy support.
2. hoist (H2)	2. hoist; Spring-loaded multi-disc brake; Resolver (hoist rotation indicator); Incl. quick couplings; Required for luffing jib operation (WIHI); Incl. rope twist prevention.
Counterweights AC-GG10 140	308,700 lb = 14 AC-GG à 22,050 lb (AC 350, AC 500-1, AC 500-2, AC 500-8, AC 650, AC 700, AC 1000, AC 1000-9).

Handling

IC-1 Plus	Smart crane control system for main boom operation enabling higher lifting capacities especially over outriggers. Enables safe use of the full capacity of the crane even in asymmetric outrigger configurations. Outriggers can be positioned independently. Capacity precalculation for +/- 30° slewing angle and radius area. In-cab lift simulation.
Fall-from-height protection system boom base section	Rail system as fall-from-height protection at the main boom base section.
Fall-from-height protection system boom base section + SSL	Rail system as fall-from-height protection at the main boom base section and SSL.
Fall-from-height protection system WIHI	Rail system as fall-from-height protection for the lattice parts WIHI-A 315.0 ft.

Extensions

WIHI-A 315.0 ft	315.0 ft; Luffing jib; Complete building set; With increments 19.7 ft; With integrated manual offset section 20°/40°; 5-sheave and 3-sheave head; Enables configuration WIHI 78.7 ft - 315.0 ft, LF 65.6 ft - 164.0 ft and HAV 19.7 ft - 118.1 ft; Only together with H2.
------------------------	---

Hook Blocks

Hook block 320-13-26-D	320-13-26-D (8,820 lb); Hook block with ramshorn hook; white with red signal stripes.
Hook block 320-11-26-D	320-11-26-D (7,720 lb); Hook block with ramshorn hook; white with red signal stripes.
Hook block 250-9-26-D	250-9-26-D (6,170 lb); Hook block with ramshorn hook; white with red signal stripes.
Hook block 200-7-26-D	200-7-26-D (5,730 lb); Hook block with ramshorn hook; white with red signal stripes.
Hook block 160-5-26-D	160-5-26-D (4,850 lb); Hook block with ramshorn hook; white with red signal stripes.
Hook block 100-3-26-D	100-3-26-D (4,410 lb); Hook block with ramshorn hook; white with red signal stripes.
Hook block 40-1-26-D	40-1-26-D (2,650 lb); Hook block with ramshorn hook; white with red signal stripes.
Hook 15-0V-E	15-0V-E (1,980 lb); Single hook with vertical swivel; red.

Further additional equipment on request!

Weight data may deviate from posted values based on road / travel configuration, equipment configuration, and component weight tolerances.

Ratings are in compliance with ASME B30.5.
Lifting capacities do not exceed 85 % of tipping load.

Consult operation manual for further details.

Note: Data published herein is intended as a guide only and shall not be construed to warrant applicability for lifting purposes. Crane operation is subject to the computer charts and operation manual both supplied with the crane.

A large rectangular area with horizontal lines, intended for taking notes.

February 2020. Product specifications and prices are subject to change without notice or obligation. The photographs and/or drawings in this document are for illustrative purposes only. Refer to the appropriate Operator's Manual for instructions on the proper use of this equipment. Failure to follow the corresponding Operator's Manual when using our equipment or to otherwise act responsibly may result in serious injury or death. The only warranty applicable to our equipment is the standard written warranty applicable to the particular product and sale and Tadano makes no other warranty, express or implied. All rights reserved. Products and services listed may be trademarks, service marks or trade-names of Tadano Ltd.

© Tadano Demag GmbH 2020. Tadano and Demag are trademarks of or licensed by Tadano Ltd. or its subsidiaries.



Tadano Demag GmbH
Europa Allee 2
66482 Zweibrücken
Germany
T +49 6332 830

info.demag@tadano.com
www.demagmobilecranes.com



Tadano Ltd. (International Division)
4-12, Kamezawa 2-chome
Sumida-ku Tokyo 130-0014, Japan
E info@tadano.com T 81-3-3621-7750
www.tadano.com